

REQUEST FOR QUOTATION FOR SERVICES

LRQS-2023-9185137

04 September 2023

UNITED NATIONS CHILDREN'S FUND (UNICEF)

wishes to invite you to submit a quotation for
**Washrooms renovation works, Health Centers from Cahul and Ungheni,
Moldova**

Offers are invited by 14 September 2023 for the supply of:

Delivery terms :

Item No	Item Description	Quantity/Unit	Unit Price	Amount
---------	------------------	---------------	------------	--------

SCHEDULE NO: 1 RENOVCUN

10 Washroom renovation works Cahul, Ungheni

Washroom renovation works Cahul, Ungheni	1	PU
--	---	----

QUOTATION FORM

The form must be completed, signed and returned to UNICEF. Quotations must be made in accordance with the instructions contained in in this Request.

The attached UNICEF's General Terms and Conditions for Institutional and Corporate contracts will apply to any resulting service contract.

The Undersigned, having read the Terms and Conditions of QUOTATION No. LRQS-2023-9185137 set out in the attached document, hereby offers to execute the services specified in the schedules at the price or prices quoted, in accordance with any specifications stated and subject to the Terms and Conditions set out or specified in the document.

Currency of Proposal: _____

Validity of Proposal: _____

Please indicate which of the following Early Payment Discount Terms are offered by you:
 10 Days 3.0% _____ 15 Days 2.5% _____ 20 Days 2.0% _____ 30 Days Net _____
 Other _____

Quotation to be addressed to: **chisinautenders@unicef.org**

Declaration

The undersigned, being a duly authorized representative of the Company, represents and declares that:

1.	The Company and its Management ¹ have not been found guilty pursuant to a final judgment or a final administrative decision of any of the following:	YES	NO
	a. fraud	<input type="checkbox"/>	<input type="checkbox"/>
	b. corruption	<input type="checkbox"/>	<input type="checkbox"/>
	c. conduct related to a criminal organisation	<input type="checkbox"/>	<input type="checkbox"/>
	d. money laundering or terrorist financing	<input type="checkbox"/>	<input type="checkbox"/>
	e. terrorist offences or offences linked toterrorist activities	<input type="checkbox"/>	<input type="checkbox"/>
	f. sexual exploitation and abuse;	<input type="checkbox"/>	<input type="checkbox"/>
	g. child labour, forced labour, human trafficking;	<input type="checkbox"/>	<input type="checkbox"/>
	h. irregularity (non-compliance with any legal or regulatory requirement applicable to the Company or its Management).	<input type="checkbox"/>	<input type="checkbox"/>

¹ #Management" means any person having powers of representation, decision-making or control over the Organization. This may include, for example, executive management and all other persons holding downstream managerial authority, anyone on the board of directors, and controlling shareholders.

2.	The Company and its Management have not been found guilty pursuant to a final judgment or a final administrative decision of grave professional misconduct.	<input type="checkbox"/>	<input type="checkbox"/>
3.	The Company and its Management are not: bankrupt, subject to insolvency or winding-up procedures, subject to the administration of assets by a liquidator or a court, in an arrangement with creditors, subject to a legal suspension of business activities, or in any analogous situation arising from a similar procedure provided for under applicable national law.	<input type="checkbox"/>	<input type="checkbox"/>
4.	The Company and its Management have not been the subject of a final judgment or a final administrative decision finding them in breach of their obligations relating to the payment of taxes or social security contributions.	<input type="checkbox"/>	<input type="checkbox"/>
5.	The Company and its Management have not been the subject of a final judgment or a final administrative decision which found they created an entity in a different jurisdiction with the intent to circumvent fiscal, social or any other legal obligations in the jurisdiction of its registered office, central administration, or principal place of business (<i>creating a shell company</i>).	<input type="checkbox"/>	<input type="checkbox"/>
6.	The Company and its Management have not been the subject of a final judgment or a final administrative decision which found the Company was created with the intent referred to in point (5) (<i>being a shell company</i>).	<input type="checkbox"/>	<input type="checkbox"/>

The UNICEF reserves the right to disqualify the Company suspend or terminate any contract or other arrangement between the UNICEF and the Company, with immediate effect and without liability, in the event of any misrepresentation made by the Company in this Declaration.

It is the responsibility of the Company to immediately inform the UNICEF of any changes in the situations declared.

This Declaration is in addition to, and does not replace or cancel, or operate as a waiver of, any terms of contractual arrangements between the UNICEF and the Company.

Signature: _____

Date: _____

Name and Title: _____

Name of the Company: _____

UNGM #: _____

Postal Address: _____

Email: _____

SPECIAL NOTES

PART I PURPOSE OF THIS REQUEST FOR QUOTATION FOR SERVICES

1. Background

UNICEF Moldova is supporting the Ungheni and Cahul focal regions to improve the quality and access to local public services for children and adolescents through capacity building for healthcare workers at the Primary Health Care Centers and development of the Early Childhood Intervention (ECI) services. As such, 2 dedicated local teams of specialists on ECI were created and able to perform assessments on young children's development, including refugees. The ECI Centers are established in the Health Centers (HC) from Cahul and Ungheni, respectively. However, to ensure a healthier start in life and keep children thriving, access to clean water, basic toilets, and good hygiene practices are pivotal. Therefore, renovation works of the washrooms are needed in both Health Centers.

To that aim, UNICEF Moldova is interested to contract a company which will renovate one washroom from HC Cahul and two double washrooms from HC Ungheni as detailed in the Scope of the Work below and the technical documents included at Annex E.

2. Solicitation

2.1 The purpose of this Request for Quotation for Services (RFQS) is to identify a suitable Contractor to execute the Works described in Statement of Work (Annex B) and the Bills of Quantities attached at Annex E within the agreed quality, budget and timeline.

2.2 This RFQS document is comprised of the following:

- This document (RFQS)
- The UNICEF General Terms and Conditions of Contract (Services) which are attached as Annex A to this document
- The full Terms of Reference/Statement of Work attached at Annex B.

2.3 This RFQS is an invitation to treat and shall not be construed as an offer capable of being accepted or as creating any contractual, other legal or restitutionary rights. No binding contract, including a process contract or other understanding or arrangement, will exist between the Bidder and UNICEF and nothing in or in connection with this RFQS shall give rise to any liability on the part of UNICEF unless and until a contract is signed by UNICEF and the successful Bidder.

PART II BID SUBMISSION PROCESS

1. Bid Submission Schedule

1.1 Acknowledgement of receipt of RFQS

Bidders are requested to inform UNICEF as soon as possible by email to Radu Bradescu at rbradescu@unicef.org that they have received this RFQS.

1.2 Questions from Bidders.

Bidders are required to submit any questions in respect of this RFQS by email to Radu Bradescu at rbradescu@unicef.org. The deadline for receipt of any questions is Tuesday 12 September 2023, 17:00.

Bidders are required to keep all questions as clear and concise as possible.

Bidders are also expected to immediately notify UNICEF in writing of any ambiguities, errors,

omissions, discrepancies, inconsistencies or other faults in any part of the RFQS, providing full details. Bidders will not benefit from such ambiguities, errors, omissions, discrepancies, inconsistencies or other faults.

UNICEF will compile the questions received. UNICEF may, at its discretion, at once copy any anonymized question and its reply to all other invited Bidders and/or post these on the UNICEF/UN tenders website and/or respond to the question at a bid conference. After any such bid conference, a Questions and Answers document may be prepared and posted on the UNICEF/UN Tenders website.

1.3 Amendments to RFQS documents. At any time prior to the Submission Deadline, UNICEF may, for any reason, whether at its own initiative or in response to a clarification requested by a prospective Bidder, modify the RFQS documents by amendment. If the RFQS was available publicly online, amendments will also be posted publicly online. Further, all prospective Bidders that have received the RFQS documents directly from UNICEF will be notified in writing of all amendments to the RFQS documents. In order to afford prospective Bidders reasonable time in which to take the amendment into account in preparing their Bids, UNICEF may, at its sole discretion, extend the Submission Deadline.

1.4 Submission Deadline. The deadline for submission of Bids is as follows:

Thursday, 14 September 2023, 11:00 EEST

Any Bids received by UNICEF after the Submission Deadline will be rejected.

1.5 Instructions for bid submission:

E-mailed submissions (strongly encouraged):

Proposals sent by e-mail must be received not later than 11:00 (EEST) on Thursday, 14 September 2023, in one e-mail containing a scanned copy of the bid duly signed and dated, with the e-mail subject "LRQS-2023-9185137 Renovation works, Cahul and Ungheni Health Centers".

The official address for e-mail submission will be chisinautenders@unicef.org. The e-mail sent shall be free from viruses and corrupted files. Max. File Size per transmission: 15 MB.

Hardcopy submissions:

Sealed bids must be received not later than 11:00 (EEST) on Thursday, 14 September 2023, in one copy, duly signed and dated.

Any delays encountered in the mail delivery will be at the risk of the bidder.

Delivery address:

UNICEF Moldova, LRQS-2023-9185137
UN House, 131, '31 August 1989' street,
Chisinau, MD-2012, Moldova

The Bidder's Bid will include all of the following labelled annexes:

- Filled and signed Quotation Form (pages 1-4 of this document), with offer lump sum provided, in MDL, without VAT
- Filled Forms 1-8 included in the Annexes C and E attached

1.6 Bid opening.

There will be no public opening of Bids.

2. Language

2.1 The Bid prepared by the Bidder and all correspondence and documents relating to the Bid exchanged by the Bidder and UNICEF, will be written in **English**. Supporting documents may be in another language. The sole responsibility for translation, including the accuracy of the translation will rest with the Bidder.

3. Validity of bids; Modification and Clarifications; Withdrawal

3.1 Validity Period.

IMPORTANT: Bidders must indicate the validity period of their Bid. Bids should be valid for a period of not less than one hundred and twenty (120) days after the Submission Deadline. A Bid valid for a shorter period of time shall not be further considered. UNICEF may request the Bidder to extend the validity period. The Bid of Bidders who decline to extend the validity of their Bid shall become disqualified as no longer valid.

3.2 Other Changes. All changes to a Bid must be received by UNICEF prior to the Submission Deadline. The Bidder must clearly indicate that the revised Bid is a modification and supersedes the earlier version of the Bid, or state the changes from the original Bid.

3.3 Withdrawal of Bid. A Bid may be withdrawn by the Bidder on e-mailed, faxed or written request received by UNICEF from the Bidder prior to Submission Deadline. Negligence on the part of the Bidder confers no right for the withdrawal of the Bid after it has been opened.

3.4 Clarifications Requested by UNICEF. During the evaluation of Bids, UNICEF may, in its sole discretion, seek clarifications from any Bidder in order for UNICEF to fully understand the Bidder's Bid and assist in the examination, evaluation and comparison of Bids. UNICEF may seek such clarifications through written communications or may request an interview with any Bidder. No change in the price or substance of the Bid will be sought, offered or permitted, except as required in order to allow for correction of arithmetical errors discovered by UNICEF.

3.5 References. UNICEF reserves the right to contact any or all references supplied by the Bidder(s) and to seek references from other sources as UNICEF deems appropriate.

4. Eligibility; Bidder Information

4.1 Bidder. The term #Bidder" refers to those companies that submit a Bid pursuant to this RFQS and #Bid" refers to all documents provided by the Bidder in its response to this RFQS. A Bidder will only be eligible for consideration if it complies with the representations set out in Part V of this RFQS, including the representations on ethical standards, including conflicts of interest.

4.2 Joint Venture, Consortium or Association

(a) If the Bidder is a group of legal entities that will form or have formed a joint venture, consortium or association at the time of the submission of the Bid, each such legal entity will confirm in their joint Bid that:

(i) they have designated one party to act as a lead entity, duly vested with authority to legally bind the members of the joint venture jointly and severally, and this will be evidenced by a Joint Venture Agreement among the legal entities, which will be submitted along with the Bid; and

(ii) if they are awarded the contract, the designated lead entity will enter into the contract with UNICEF, who will be acting for and on behalf of all the member entities comprising the joint

venture.

(b) After the Bid has been submitted to UNICEF, the lead entity identified to represent the joint venture will not be altered without the prior written consent of UNICEF.

(c) If a joint venture's Bid is the Bid selected for award, UNICEF will award the contract to the joint venture, in the name of its designated lead entity. The lead entity will sign the contract for and on behalf of all other member entities.

4.3 Bids from Government Organizations. The eligibility of Bidders that are wholly or partly owned by the Government will be subject to UNICEF's further evaluation and review of various factors such as being registered as an independent entity, the extent of Government ownership/share, receipt of subsidies, mandate, access to information in relation to these RFQS documents, and others that may lead to undue advantage against other Bidders, and the eventual rejection of the Bid.

4.4 Bids from organizations where the sole proprietor is a former or retired UNICEF/UN staff member. Any organization whose sole proprietor is a former or retired staff member of UNICEF (or any other United Nations organization) which submits a Bid must disclose this previous United Nations employment at the time of submission. Any such Bid will be treated as though the Bid came from an individual for the purposes of UNICEF's standard conditions on contracting former and retired members of staff.

5. Preparation of Offer

5.1 Bidders are responsible to inform themselves in preparing their Bid. In this regard, the Bidders will ensure that they:

- Examine all terms, requirements and formal submission instructions included in the RFQS documents (including the Instructions to Bidders section);
- Review the RFQS to ensure that they have a complete copy of all documents;
- Review the standard UNICEF Contractual Provisions and the UNICEF General Terms and Conditions of Contract (Services) for the supply of services publicly available on the UNICEF Supply website: http://www.unicef.org/supply/index_procurement_policies.html;
- Review the UNICEF policies publicly available on the UNICEF Supply website: http://www.unicef.org/supply/index_procurement_policies.html. In particular, Bidders should familiarize themselves with the obligations imposed on suppliers and their personnel and sub-contractors under the UNICEF Policy Prohibiting and Combatting Fraud and Corruption and the UNICEF Policy on Conduct Promoting the Protection and Safeguarding of Children;
- Fully inform and satisfy themselves as to requirements of any relevant authorities and laws that apply, or may in the future apply, to the supply of the services.

Bidders acknowledge that UNICEF, its directors, employees and agents make no representations or warranties (express or implied) as to the accuracy or completeness of this RFQS or any other information provided to the Bidders.

5.2 Failure to meet all requirements and instructions in the RFQS documents or to provide all requested information will be at the Bidder's own risk, and may result in rejection of the Bidder's Bid.

5.3 The Bid must be organized to follow the format of this RFQS. Each Bidder must respond to the stated requests or requirements, and indicate that the Bidder understands and confirms acceptance of UNICEF's stated requirements. The Bidder should identify any substantive assumption made in preparing its offer. The deferral of a response to a question or issue to any contract negotiation stage is not acceptable. Any item not specifically addressed in the Bid will be deemed as accepted by the Bidder. Incomplete or inadequate responses, lack of response or misrepresentation in responding to any questions will affect the evaluation of the Bid.

5.4 All references to descriptive materials should be included in the appropriate Bid paragraph, though the material/documents themselves may be provided as annexes to the Bid.

5.5 Important: The completed and signed Bid Form (pages 1-4) must be submitted along with the bidder submission. The Bid Form must be signed by a duly authorized representative of the Organization/Company.

5.6 Bids must be clearly marked with the RFQS number.

5.7 If answer sheets are provided by UNICEF then these must be completed by the Bidder.

5.8 Each Bidder acknowledges that its participation in any stage of the solicitation process for this RFQS is at its own risk and cost. The Bidder is responsible for, and UNICEF is not responsible for, the costs of preparing its Bid or response to this RFQS, attendance at any bid conference, site visit, meetings or oral presentations, regardless of the conduct or outcome of the solicitation process.

5.9 The Bidder's Bid will include all of the following labelled annexes:

- Filled and signed Quotation Form (pages 1-4 of this document), with offer lump sum provided, in MDL, without VAT

- Filled Forms 1-8 included in the Annexes C and E attached

6. Bid Documents; Confidentiality

6.1 This RFQS, together with all Bid documents provided by the Bidder to UNICEF will be considered the property of UNICEF and Bid documents will not be returned to the Bidders.

6.2 Information contained in the Bid documents, which the Bidder considers to be its confidential information, should be clearly marked "confidential", next to the relevant part of the text, and UNICEF will treat such information accordingly.

6.3 All information and documents provided to the Bidders by UNICEF ("RFQS Materials") shall be treated as confidential by the Bidders. If the Bidder declines to respond to this RFQS, or, if the Bid is rejected or unsuccessful, the Bidder will promptly return all such RFQS Materials to UNICEF, or destroy or delete all such RFQS Materials. The Bidder shall not use the RFQS Materials for any purpose other than the purpose of preparing a Bid and shall not disclose the RFQS Materials to any third party, except: (a) with the prior written consent of UNICEF; (b) where the third party is assisting the Bidder in preparing the Bid, provided the Bidder has previously ensured that party's adherence to this duty of confidentiality; (c) if the relevant RFQS Materials are at the time of this RFQS lawfully in the possession of the Bidder through a party other than UNICEF; (d) if required by law, and provided that the Bidder has previously informed UNICEF in writing of its obligation to disclose the RFQS Materials; or (e) if the RFQS Materials are generally and publicly available other than as a result of breach of confidence by the person receiving the RFQS Materials.

7. Multiple bids and bids from related organizations

7.1 Bidders shall not submit more than one Bid as part of this RFQS process.

7.2 If the Bidder is a group of legal entities that will form or have formed a joint venture, consortium or association at the time of the submission of the Bid then neither the lead entity nor the member entities of the joint venture may submit another Bid, either in its own capacity or as a lead entity or a member entity for another joint venture submitting another Bid.

7.3 UNICEF reserves the right to reject separate Bids submitted by two or more Bidders if the Bidders are related organizations and are found to have any of the following:

- (a) they have at least one controlling partner, director or shareholder in common; or
- (b) any one of them receive or have received any direct or indirect subsidy from the other(s); or
- (c) they have a relationship with each other, that gives one or more Bidders access to confidential information about, or influence over, the other Bid(s); or
- (d) they are subcontractors to each other's Bid, or a subcontractor to one Bid also submits another Bid under its name as lead Bidder; or
- (e) an expert proposed to be in the team of one Bidder participates in more than one Bid received for this solicitation process.

PART III AWARD/ADJUDICATION OF BIDS

1. Award

1.1 Evaluation.

The evaluation is carried out by UNICEF in accordance with UNICEF's regulations, rules and practices and all determinations are made in UNICEF's sole discretion.

After the opening of Bids, UNICEF will carry out the following steps in the following order:

First, UNICEF will evaluate each Bid for compliance with the mandatory requirements of this RFQS. Responses deemed not to meet all of the mandatory requirements will be considered non-compliant and rejected at this stage without further consideration. Failure to comply with any of the terms and conditions contained in this RFQS, including provision of all required information, may result in a response or Bid being disqualified from further consideration.

Second, UNICEF will evaluate Bids for compliance with the technical requirements stated in this RFQS and undertake a commercial evaluation.

UNICEF will then (subject to the various rights of UNICEF detailed in this RFQS) award the contract(s) to the vendor(s) providing the lowest priced technically compliant Bid(s).

1.2 Partial Bids. PARTIAL BIDS ARE NOT ACCEPTABLE.

1.3 Multiple Arrangements. UNICEF reserves the right to make multiple arrangements for any service(s) where UNICEF considers it in its best interest to do so.

1.4 Award Notification. UNICEF will only notify the Bidder(s) that has/have been awarded the contract(s) resulting from this solicitation process; UNICEF may, but is not required to, notify the other Bidders of the outcome of this solicitation process.

2. General Terms And Conditions Of Contract (Services)

2.1 UNICEF's General Terms and Conditions of Contract (Services) will apply to any contracts awarded in connection with this RFQS. By signing the Quotation Form, each Bidder is deemed to have confirmed its acceptance of the UNICEF General Terms and Conditions (Services). The Bidder understands that if it proposes any amendments or additional terms to the UNICEF General Terms and Conditions (Services), these must be clearly detailed in the Bid and may negatively affect the evaluation of the Bid.

3. Rights of UNICEF

3.1 UNICEF reserves the following rights:

(a) to accept any Bid, in whole or in part; to reject any or all Bids; or to cancel this solicitation process in its entirety;

(b) to verify any information contained in Bidder's response (and the Bidder will provide UNICEF with its reasonable cooperation with such verification);

(c) to invalidate any Bid received from a Bidder that, in UNICEF's sole opinion has previously failed to perform satisfactorily or complete contracts on time, or UNICEF believes is not in a position to perform the contract;

(d) to invalidate any Bid that, in UNICEF's sole opinion, fails to meet the requirements and instructions stated in this RFQS;

(e) to withdraw an award to a Bidder at any time up until a contract has been signed with such Bidder. UNICEF is not required to provide any justification, but will give notice prior to any such withdrawal of award.

3.2 UNICEF is not liable to any Bidder for any costs, expense or loss incurred or suffered by such Bidder in connection with this RFQS or solicitation process, including, but not limited to, any costs, expense or loss incurred as result of UNICEF exercising any of its rights in paragraph 3.1 above.

PART IV REQUIREMENTS

1. Price and Payment

1.1 Price. The fee for the services and deliverables will be treated as inclusive of all costs, expenses, charges or fees that the Bidder may incur in connection with the performance of the work. The Bidder is invited to offer any unconditional discounts. Further, the Bidder may offer early payment discounts, i.e. payment within a specific period of time faster than UNICEF's standard payment terms of 30 days.

1.2 Payment Terms. Invoices may be issued to UNICEF only after the services (or components of the services) have been provided and the deliverables (or installments of the deliverables) have been delivered (a) in accordance with the contract and (b) to UNICEF's satisfaction. The standard terms of payment are net 30 days, after receipt of invoice. Payment will be effected by bank transfer in the currency of the contract.

The Bidder will suggest a payment schedule for the contract that is linked to clear milestones and/or deliverables identified in the Terms of Reference/Statement of Work.

1.3 Currency.

(a) The currency of the Bid shall be in MDL. UNICEF will reject any Bids submitted in another currency.

(b) If the above paragraph (a) explicitly permits two or more specified currencies for the Bids, then for evaluation purposes only, offers submitted in a currency other than US Dollars will be converted into US Dollars using the United Nations rate of exchange in effect on the submission deadline date.

1.4 Taxes. Article II, Section 7, of the Convention on the Privileges and Immunities provides, inter alia, that the United Nations, including UNICEF as a subsidiary organ, is exempt from all

direct taxes, except charges for public utility services, and is exempt from customs restrictions, duties, and charges of a similar nature in respect of articles imported or exported for its official use. All prices/rates quoted in the Bid must be net of any direct taxes and any other taxes and duties, unless otherwise specified in the RFQS documents.

2. Implementation

2.1 No Reliance. Except as expressly set out in the RFQS documents, UNICEF will have no obligation to provide any assistance to the contractor and UNICEF makes no representations as to the availability of any facilities, equipment, materials, systems or licenses which may be helpful or useful for the performance of the work. If the Bidder requires any facilities, equipment, materials, systems or licenses in order to do the work, this must be explicitly detailed in its Bid.

2.2 Sub-contractors. Bidders must identify in their Bid, any products which may be offered by themselves, but originate from another supplier and/or country. Further, bidders must identify in their Bid any planned subcontracting of services. All subcontracting arrangements will be reviewed by UNICEF as part of its evaluation of the Bid.

2.3 Experts. If so required in the Terms of Reference/Statement of Work each key expert profile requested in the Terms of Reference/Statement of Work must sign an exclusivity and availability statement. The purpose of Exclusivity and Availability Statement is as follows:

(a) The key experts proposed in the Bid must not be part of any other Bidder's Bid being submitted for this RFQS process. They must therefore engage themselves exclusively to the Bidder.

(b) Each key expert must also undertake to be available, able and willing to work for all the period foreseen for his/her input during the implementation of the contract as indicated in the Terms of Reference/Statement of Work and the Bid.

Having selected a Bid partly on the basis of an evaluation of the key experts presented in the Bid, UNICEF expects the contract to be executed by these specific experts. As the expected date of mobilization is given in the RFQS, UNICEF will only consider substitutions after the deadline for the submission of offers in cases of unexpected delays in the commencement date beyond the control of the Bidder, or exceptionally because of the incapacity of a key expert for health reasons or due to force majeure or other circumstances which may justify a replacement and which would not have any effect on the selection of the Bid. The desire of a Bidder to use an expert on another project or a change of mind on the part of an expert about the contract will not be accepted as a reason for substitution of any of the key experts.

2.4 Joint Ventures. The description of the organization of the joint venture/consortium/association must clearly define the expected role of each of the entities in the joint venture in delivering the requirements of this RFQS both in the Bid and the Joint Venture Agreement. All entities that comprise the joint venture will be subject to the eligibility and qualification assessment by UNICEF.

Where a joint venture is presenting its track record and experience in a similar undertaking as those required in this RFQS, it should present such information in the following manner:

- a) Those that were undertaken together by the joint venture; and
- b) Those that were undertaken by the individual entities of the joint venture expected to be involved in the performance of the services defined in this RFQS.

Previous contracts completed by individual experts working privately but who are permanently or were temporarily associated with any of the member firms cannot be claimed as the experience of the joint venture or those of its members, but should only be claimed by the individual experts

themselves in their presentation of their individual credentials.

3. Liquidated Damages

3.1 Liquidated damages. Any contracts awarded in connection with this RFQS will include the following clause on liquidated damages:

In addition to, and without prejudice to any of the other rights and remedies of UNICEF including, but not limited to, those set out in the UNICEF General Terms and Conditions of Contract (Services), if the Contractor fails to provide the Services or the Deliverables in accordance with the time schedule set out in the Contract, or if UNICEF determines that the Services or Deliverables do not conform to the requirements of the Contract, UNICEF may claim liquidated damages from the Contractor and, at UNICEF's option, the Contractor will pay such liquidated damages to UNICEF or UNICEF will deduct such liquidated damages from the Contractor's invoice(s). Such liquidated damages will be calculated as follows: one half of one per cent (0.5%) of the Contract Fee for the delayed Services and Deliverables for each day of delay, or in the case of a Fee calculated on a time-based rate, one half of one per cent (0.5%) of the time-based rate for all the Contractor Personnel required to provide the relevant Services or Deliverables, until performance of conforming Services or delivery of conforming Deliverables, up to a maximum of ten per cent (10%) of the value of the Contract. The payment or deduction of such liquidated damages will not relieve the Contractor from any of its other obligations or liabilities pursuant to the Contract.

PART V BIDDER REPRESENTATIONS

1. Price Most Favoured Customer

1.1 The Bidder confirms that the fees, rates and charges and related pricing terms with respect to the services specified in the Bid are the most favourable pricing terms available to any customer of the Bidder (or any of the Bidder's affiliates). If at any time during the term of any contract resulting from the Bid, any other customer of the Bidder (or of any of the Bidder's affiliates) obtains more favourable pricing terms than those provided to UNICEF, the Bidder will retroactively adjust the fee and related pricing terms under the contract to conform to the more favourable terms and the Bidder will promptly pay UNICEF any amounts owing to UNICEF as a result of such retroactive fee adjustment.

2. General Representations

By submitting its Bid in response to this RFQS, the Bidder confirms to UNICEF as at the Submission Deadline:

2.1 The Bidder has (a) the full authority and power to submit the Bid and to enter into any resulting contract, and (b) all rights, licenses, authority and resources necessary, as applicable, to develop, source and supply the services and to perform its other obligations under any resulting contract. The Bidder has not and will not enter into any agreement or arrangement that restrains or restricts any person's rights to use, sell, dispose of or otherwise deal with any service, deliverable or outcome that may be acquired under any resulting contract.

2.2 All of the information it has provided to UNICEF concerning the services and the Bidder is true, correct, accurate and not misleading.

2.3 The Bidder is financially solvent and is able to supply the services to UNICEF in accordance with the requirements described in this RFQS.

2.4 The use or supply of the services does not and will not infringe any patent, design, trade-name or trade-mark.

2.5 The development and supply of the services has complied, does comply, and will comply with all applicable laws, rules and regulations.

2.6 The Bidder will fulfill its commitments with the fullest regard to the interests of UNICEF and will refrain from any action which may adversely affect UNICEF or the United Nations.

2.7 It has the personnel, experience, qualifications, facilities, financial resources and all other

skills and resources to perform its obligations under any resulting contract.

2.8 The Bidder agrees to be bound by the decisions of UNICEF, including but not limited to, decisions as to whether the Bidder's Bid meets the requirements and instructions stated in this RFQS and the results of the evaluation process.

3. Ethical Standards

UNICEF requires that all Bidders observe the highest standard of ethics during the entire solicitation process, as well as the duration of any contract that may be awarded as a result of this solicitation process. UNICEF also actively promotes the adoption by its suppliers of robust policies for the protection and safeguarding of children and the prevention and prohibition of sexual exploitation and sexual abuse.

By submitting its Bid in response to this RFQS, the Bidder makes the following representations and warranties to UNICEF as at the Submission Deadline:

3.1 In respect of all aspects of the solicitation process the Bidder has disclosed to UNICEF any situation that may constitute an actual or potential conflict of interest or could reasonably be perceived as a conflict of interest. In particular, the Bidder has disclosed to UNICEF if it or any of its affiliates is, or has been in the past, engaged by UNICEF to provide services for the preparation of the design, specifications, cost analysis/estimation, and other documents to be used for the procurement of the services requested under this RFQS; or if it or any of its affiliates has been involved in the preparation and/or design of the programme/project related to the services requested under this RFQS.

3.2 The Bidder has not unduly obtained, or attempted to obtain, any confidential information in connection with the solicitation process and any contract that may be awarded as a result of this solicitation process.

3.3 No official of UNICEF or of any United Nations System organisation has received from or on behalf of the Bidder, or will be offered by or on behalf of the Bidder, any direct or indirect benefit in connection with this RFQS including the award of the contract to the Bidder. Such direct or indirect benefit includes, but is not limited to, any gifts, favours or hospitality.

3.4 The following requirements with regard to former UNICEF officials have been complied with and will be complied with:

(a) During the one (1) year period after an official has separated from UNICEF, the Bidder may not make a direct or indirect offer of employment to that former UNICEF official if that former UNICEF official was, during the three years prior to separating from UNICEF, involved in any aspect of a UNICEF procurement process in which the Bidder has participated.

(b) During the two (2) year period after an official has separated from UNICEF, that former official may not, directly or indirectly on behalf of the Bidder, communicate with UNICEF, or present to UNICEF, about any matters that were within such former official's responsibilities while at UNICEF.

3.5 Neither the Bidder nor any of its affiliates, or personnel or directors, is subject to any sanction or temporary suspension imposed by any United Nations System organisation or other international inter-governmental organisation. The Bidder will immediately disclose to UNICEF if it or any of its affiliates, or personnel or directors, becomes subject to any such sanction or temporary suspension during the term of any resulting contract. If the Bidder or any of its affiliates, or personnel or directors becomes subject to any such sanction or temporary suspension during the term of the contract, UNICEF will be entitled to suspend the contract for a

period of time up to thirty (30) days or terminate the contract, at its sole choice, with immediate effect upon delivery of a written notice of suspension or termination, as the case may be, to the Bidder. If UNICEF chooses to suspend the contract it will be entitled to terminate the contract at the end of the thirty (30) days' suspension at UNICEF's sole choice.

3.6 The Bidder will (a) observe the highest standard of ethics; (b) use its best efforts to protect UNICEF against fraud, in the solicitation process and in the performance of any resulting contract; and (c) comply with the applicable provisions of UNICEF's Policy Prohibiting and Combatting Fraud and Corruption which can be accessed on the UNICEF website at http://www.unicef.org/supply/index_procurement_policies.html. In particular, the Bidder will not engage, and will ensure that its personnel, agents and sub-contractors do not engage, in any corrupt, fraudulent, coercive, collusive or obstructive conduct as such terms are defined in UNICEF's Policy Prohibiting and Combatting Fraud and Corruption.

3.7 The Bidder will comply with all laws, ordinances, rules and regulations bearing upon its participation in this solicitation and the UN Supplier Code of Conduct (available at the United Nations Global Marketplace website - www.ungm.org).

3.8 Neither the Bidder nor any of its affiliates, is engaged, directly or indirectly, (a) in any practice inconsistent with the rights set forth in the Convention on the Rights of the Child, including Article 32, or the International Labour Organisation's Convention Concerning the Prohibition and Immediate Action for the Elimination of the Worst Forms of Child Labour, No. 182 (1999); or (b) in the manufacture, sale, distribution, or use of anti-personnel mines or components utilised in the manufacture of anti-personnel mines.

3.9 The Bidder has taken and will take all appropriate measures to prevent sexual exploitation or abuse of anyone by its personnel including its employees or any persons engaged by the Bidder to perform any services in the Bidder's participation in this solicitation. For these purposes, sexual activity with any person less than eighteen years of age, regardless of any laws relating to consent, will constitute the sexual exploitation and abuse of such person. The Bidder has taken and will take all appropriate measures to prohibit its personnel including its employees or other persons engaged by the Bidder, from exchanging any money, goods, services, or other things of value, for sexual favours or activities or from engaging in any sexual activities that are exploitive or degrading to any person.

3.10 The Bidder confirms that it has read UNICEF's Policy on Conduct Promoting the Protection and Safeguarding of Children. The Bidder will ensure that its Personnel understand the notification requirements expected of them and will establish and maintain appropriate measures to promote compliance with such requirements. The Bidder will further cooperate with UNICEF's implementation of this Policy.

3.11 The Bidder will inform UNICEF as soon as it becomes aware of any incident or report that is inconsistent with the undertakings and confirmations provided in this Article 3.

3.12 Each of the provisions in this Article 3 of Part V constitutes an essential condition of participation in this solicitation process. In the event of a breach of any of these provisions, UNICEF is entitled to disqualify the Bidder from this solicitation process and/or any other solicitation process, and to terminate any contract that may have been awarded as a result of this solicitation process, immediately upon notice to the Bidder, without any liability for termination charges or any liability of any kind. In addition, the Bidder may be precluded from doing business with UNICEF and any other entity of the United Nations System in the future.

4. Audit

4.1 From time to time, UNICEF may conduct audits or investigations relating to any aspect of a contract awarded in relation to this RFQS, including but not limited to the award of the contract and the Bidder's compliance with the provisions of Article 3 above. The Bidder will provide its full and timely cooperation with any such audits or investigations, including (but not limited to) making its personnel and any relevant data and documentation available for the purposes of such audits or investigations, at reasonable times and on reasonable conditions, and granting UNICEF and those undertaking such audits or investigations access to the Bidder's premises at reasonable times and on reasonable conditions in connection with making its personnel and any relevant data and documentation available. The Bidder will require its sub-contractors and its agents to provide reasonable cooperation with any audits or investigations carried out by UNICEF.

SPECIAL TERMS AND CONDITIONS

INSTRUCTION TO BIDDERS

1. BID SUBMISSION

1.1 Bids shall be submitted in the manner specified in this solicitation document.

1.2 Bids must be clearly marked with the RFQ(S) number.

2. UNGM REGISTRATION

2.1 UNICEF is part of the United Nations Global Marketplace(UNGM). Accordingly, all bidders are encouraged to become a UNICEF vendor by creating a vendor profile in the UNGM website: www.ungm.org

ANNEX A GENERAL TERMS AND CONDITIONS

GENERAL TERMS AND CONDITIONS OF CONTRACT (Services)

Definitions and UNICEF Supply Website

1.1 In these General Terms and Conditions (Services), the following terms have the following meaning:

"Affiliates" means, with respect to the Contractor, any of its corporate affiliates or associates, including parent entities, subsidiaries, and other entities in which it owns a substantial interest.

"Confidential Information" means information or data that is designated as confidential at the time of exchange between the Parties or promptly identified as confidential in writing when furnished in intangible form or disclosed orally, and includes information, the confidential or proprietary nature of which, is or should be reasonably apparent from the inherent nature, quality or characteristics of such information.

"Contract" means the services contract that incorporates these General Terms and Conditions of Contract (Services). It includes contracts for services issued by UNICEF, whether or not they are issued under a long-term arrangement or similar contract.

"Contractor" means the contractor named in the Contract.

"Deliverables" means the work product and other output of the Services required to be delivered by Contractor as part of the Services, as specified in the relevant section of the Contract.

"Disabling Code" means any virus, back door, timer or other limiting routine, instruction or design, or other malicious, illicit or similar unrequested code that may have the consequence (whether by design or unintentionally) of disrupting, disabling, harming, circumventing security controls or otherwise impeding in any manner the normal operation or performance of (i) any software or service or (ii) any UNICEF information system or network.

"End User" means, in the event that the Services or Deliverables involve the use of any information systems, any and all UNICEF employees, consultants and other personnel and any other external users collaborating with UNICEF, in each case, authorized by UNICEF to access and use the Services and/or Deliverables.

"Fee" is defined in Article 3.1.

"Host Government" means a Government with which UNICEF has a programme of development cooperation, and includes a Government of a country in which UNICEF provides humanitarian assistance.

Contractor's "Key Personnel" are: (i) Personnel identified in the proposal as key individuals (as a minimum, partners, managers, senior auditors) to be assigned for participation in the performance of the Contract; (ii) Personnel whose resumes were submitted with the proposal; and (iii) individuals who are designated as key personnel by agreement of the Contractor and UNICEF during negotiations.

"Parties" means the Contractor and UNICEF together and a "Party" means each of the Contractor and UNICEF.

Contractor's "Personnel" means the Contractor's officials, employees, agents, individual sub-contractors and other representatives.

"Security Incident" means, with respect to any information system, service or network used in the delivery of the Services or Deliverables, one or more events that (a) indicates that the security of such information system, service, or network may have been breached or compromised and (b) that such breach or compromise could very likely compromise the security of UNICEF's Confidential Information or weaken or impair UNICEF's operations. Security Incident includes any actual, threatened or reasonably suspected unauthorized access to, disclosure of, use of or acquisition of UNICEF Data that compromises the security, confidentiality, or integrity of the UNICEF Data, or the ability of UNICEF or End Users to access the UNICEF Data.

"Services" means the services specified in the relevant section of the Contract.

"UNICEF Data" means any and all information or data in digital form or processed or held in digital form that (a) are provided to the Contractor by, or on behalf of, UNICEF and/or End Users under the Contract or through UNICEF's and/or End Users' use of the Services or in connection with the Services, or (b) are collected by the Contractor in the performance of the Contract.

"UNICEF Supply Website" means UNICEF's public access webpage available at http://www.unicef.org/supply/index_procurement_policies.html, as may be updated from time to time.

1.2 These General Terms and Conditions of Contract, UNICEF's Policy Prohibiting and Combatting Fraud

and Corruption, the UNICEF's Policy on Conduct Promoting the Protection and Safeguarding of Children, the UN Supplier Code of Conduct and UNICEF's Information Disclosure Policy referred to in the Contract, as well as other policies applicable to the Contractor, are publicly available on the UNICEF Supply Website. The Contractor represents that it has reviewed all such policies as of the effective date of the Contract.

2. Provision of Services and Deliverables; Contractor's Personnel; Sub-Contractors

Provision of Services and Deliverables

2.1 The Contractor will provide the Services and deliver the Deliverables in accordance with the scope of work set out in the Contract, including, but not limited to, the time for delivery of the Services and Deliverables, and to UNICEF's satisfaction. Except as expressly provided in the Contract, the Contractor will be responsible at its sole cost for providing all the necessary personnel, equipment, material and supplies and for making all arrangements necessary for the performance and completion of the Services and delivery of the Deliverables under the Contract.

2.2 The Contractor acknowledges that, other than as expressly set out in the Contract, UNICEF will have no obligation to provide any assistance to the Contractor and UNICEF makes no representations as to the availability of any facilities, equipment, materials, systems or licenses which may be helpful or useful for the fulfillment by the Contractor of its obligations under the Contract. If UNICEF provides access to and use of UNICEF premises, facilities or systems (whether on site or remotely) to the Contractor for the purposes of the Contract, the Contractor will ensure that its Personnel or sub-contractors will, at all times (a) use such access exclusively for the specific purpose for which the access has been granted and (b) comply with UNICEF's security and other regulations and instructions for such access and use, including, but not limited to, UNICEF's information security policies. The Contractor will ensure that only those of its Personnel that have been authorized by the Contractor, and approved by UNICEF, have access to UNICEF's premises, facilities or systems.

2.3 The Contractor will use its best efforts to accommodate reasonable requests for changes (if any) to the scope of work of the Services or time for provision of the Services or delivery of the Deliverables. If UNICEF requests any material change to the scope of work or time for delivery, UNICEF and the Contractor will negotiate any necessary changes to the Contract, including as to the Fee and the time schedule under the Contract. Any such agreed changes will become effective only when they are set out in a written amendment to the Contract signed by both UNICEF and the Contractor. Should the Parties fail to agree on any such changes within thirty (30) days, UNICEF will have the option to terminate the Contract without penalty notwithstanding any other provision of the Contract.

2.4 The Contractor will neither seek nor accept instructions from any entity other than UNICEF (or entities authorized by UNICEF to give instructions to the Contractor) in connection with the provision of the Services or development and delivery of the Deliverables.

2.5 Title to any equipment and supplies which may be provided to the Contractor by UNICEF, will remain with UNICEF. Such equipment and supplies will be returned to UNICEF at the conclusion of the Contract or when no longer needed by the Contractor in the same condition as when they were provided to the Contractor, subject to normal wear and tear. The Contractor will pay UNICEF the value of any loss of, damage to, or degradation of, the equipment and supplies beyond normal wear and tear.

Non-conforming Services and Consequences of Delay

2.6 If the Contractor determines it will be unable to provide the Services or deliver the Deliverables by the date stipulated in the Contract, the Contractor will (i) immediately consult with UNICEF to determine the most expeditious means for delivery of the Services and/or Deliverables; and (ii) take necessary action to expedite delivery of the Services and/or Deliverables, at the Contractor's cost (unless the delay is due to force majeure as defined in Article 6.8 below), if reasonably so requested by UNICEF.

2.7 The Contractor acknowledges that UNICEF may monitor the Contractor's performance under the Contract and may at any time evaluate the quality of the Services provided and the Deliverables to determine whether or not the Services and Deliverables conform to the Contract. The Contractor agrees to provide its full cooperation with such performance monitoring and evaluation, at no additional cost or expense to UNICEF, and will provide relevant information as reasonably requested by UNICEF, including, but not limited to, the date of receipt of the Contract, detailed status updates, costs to be charged and payments made by UNICEF or pending. Neither the evaluation of the Services and Deliverables, nor failure to undertake any such evaluation, will relieve the Contractor of any of its warranty or other obligations under the Contract.

2.8 If the Services or Deliverables provided by the Contractor do not conform to the requirements of the Contract or are delivered late or incomplete, without prejudice to any of its other rights and remedies, UNICEF can, at its option:

ANNEX A GENERAL TERMS AND CONDITIONS

(a) by written notice, require the Contractor, at the Contractor's expense, to remedy its performance, including any deficiencies in the Deliverables, to UNICEF's satisfaction within thirty (30) days after receipt of UNICEF's notice (or within such shorter period as UNICEF may determine, in its sole discretion, is necessary as specified in the notice);

(b) require the Contractor to refund all payments (if any) made by UNICEF in respect of such non-conforming or incomplete performance;

(c) procure all or part of the Services and/or Deliverables from other sources, and require the Contractor to pay UNICEF for any additional cost beyond the balance of the Fee for such Services and Deliverables;

(d) give written notice to terminate the Contract for breach, in accordance with Article 6.1 below, if the Contractor fails to remedy the breach within the cure period specified in Article 6.1 or if the breach is not capable of remedy;

(e) require the Contractor to pay liquidated damages as set out in the Contract.

2.9 Further to Article 11.5 below, the Contractor expressly acknowledges that if UNICEF takes delivery of Services or Deliverables that have been delivered late or otherwise not in full compliance with the requirements of the Contract, this does not constitute a waiver of UNICEF's rights in respect of such late or non-compliant performance.

Contractor's Personnel and Sub-Contractors

2.10 The following provisions apply with regard to the Contractor's Personnel:

(a) The provisions of Article 7 (Ethical Standards) will apply to the Contractor's Personnel as expressly stated in Article 7.

(b) The Contractor will be responsible for the professional and technical competence of the Personnel it assigns to perform work under the Contract and will select professionally qualified, reliable and competent individuals who will be able to effectively perform the obligations under the Contract and who, while doing so, will respect the local laws and customs and conform to a high standard of moral and ethical conduct.

(c) The qualifications of any Personnel whom the Contractor may assign or may propose to assign to perform any obligations under the Contract will be substantially the same as, or better than, the qualifications of any personnel originally proposed by the Contractor.

(d) At any time during the term of the Contract, UNICEF can make a written request that the Contractor replace one or more of the assigned Personnel. UNICEF will not be required to give an explanation or justification for this request. Within seven (7) working days of receiving UNICEF's request for replacement the Contractor must replace the Personnel in question with Personnel acceptable to UNICEF. This provision also extends to Personnel of the Contractor who have "account manager" or "relationship manager" type functions.

(e) If one or more of Contractor's Key Personnel become unavailable, for any reason, for work under the Contract, the Contractor will (i) notify the UNICEF contracting authority at least fourteen (14) days in advance; and (ii) obtain the UNICEF contracting authority's approval prior to making any substitution of Key Personnel. In notifying the UNICEF contracting authority, the Contractor will provide an explanation of the circumstances necessitating the proposed replacement(s) and submit justification and qualification of replacement Personnel in sufficient detail to permit evaluation of the impact on the engagement.

(f) The approval of UNICEF of any Personnel assigned by the Contractor (including any replacement Personnel) will not relieve the Contractor of any of its obligations under the Contract. The Contractor's Personnel, including individual sub-contractors, will not be considered in any respect as being the employees or agents of UNICEF.

(g) All expenses of the withdrawal or replacement of the Contractor's Personnel will, in all cases, be borne exclusively by the Contractor.

2.11 The Contractor will obtain the prior written approval and clearance of UNICEF for all institutional sub-contractors it proposes to use in connection with the Contract. The approval of UNICEF of a sub-contractor will not relieve the Contractor of any of its obligations under the Contract. The terms of any sub-contract will be subject to, and will be construed in a manner that is fully in accordance with, all of the terms and conditions of the Contract.

2.12 The Contractor confirms that it has read UNICEF's Policy on Conduct Promoting the Protection and

Safeguarding of Children. The Contractor will ensure that its Personnel understand the notification requirements expected of them and will establish and maintain appropriate measures to promote compliance with such requirements. The Contractor will further cooperate with UNICEF's implementation of this policy.

2.13 The Contractor will supervise its Personnel and sub-contractors and will be fully responsible and liable for all Services performed by its Personnel and sub-contractors and for their compliance with the terms and conditions of the Contract.

2.14 The Contractor will comply with all applicable international standards and national labor laws, rules and regulations relating to the employment of national and international staff in connection with the Services, including, but not limited to, laws, rules and regulations associated with the payment of the employer's portions of income tax, insurance, social security, health insurance, worker's compensation, retirement funds, severance or other similar payments. Without limiting the provisions of this Article 2 or Article 4 below, the Contractor will be fully responsible and liable for, and UNICEF will not be liable for (a) all payments due to its Personnel and sub-contractors for their services in relation to the performance of the Contract; (b) any action, omission, negligence or misconduct of the Contractor, its Personnel and sub-contractors; (c) any insurance coverage which may be necessary or desirable for the purpose of the Contract; (d) the safety and security of the Contractor's Personnel and sub-contractors' personnel; or (e) any costs, expenses, or claims associated with any illness, injury, death or disability of the Contractor's Personnel and sub-contractors' personnel, it being understood that UNICEF will have no liability or responsibility with regard to any of the events referred to in this Article 2.14.

3. Fee; Invoicing; Tax Exemption; Payment Terms

3.1 The fee for the Services is the amount in the currency specified in the fee section of the Contract (the "Fee"), it being understood that such amount is specified in United States dollars unless otherwise expressly provided for in the fee section of the Contract. Unless expressly stated otherwise in the Contract, the Fee is inclusive of all costs, expenses, charges or fees that the Contractor may incur in connection with the performance of its obligations under the Contract; provided that, without prejudice to or limiting the provisions of Article 3.3 below, all duties and other taxes imposed by any authority or entity must be separately identified. It is understood and agreed that the Contractor will not request any change to the Fee after the Services or Deliverables have been provided and that the Fee cannot be changed except by written agreement between the Parties before the relevant Service or Deliverable is provided. UNICEF will not agree to changes to the Fee for modifications or interpretations of the scope of work if those modifications or interpretations of the scope of work have already been initiated by the Contractor. UNICEF will not be liable to pay for any work conducted or materials provided by the Contractor that are outside the scope of work or were not authorized in advance by UNICEF.

3.2 The Contractor will issue invoices to UNICEF only after the Contractor has provided the Services (or components of the Services) and delivered the Deliverables (or installments of the Deliverables) in accordance with the Contract and to UNICEF's satisfaction. The Contractor will issue (a) one (1) invoice in respect of the payment being sought, in the currency specified in the Contract and in English, indicating the Contract identification number listed on the front page of the Contract; and (b) provide a clear and specific description of the Services provided and Deliverables delivered, as well as supporting documentation for reimbursable expenses if any, in sufficient detail to permit UNICEF to verify the amounts stated in the invoice.

3.3 The Contractor authorizes UNICEF to deduct from the Contractor's invoices any amount representing direct taxes (except charges for utilities services) and customs restrictions, duties and charges of a similar nature in respect of articles imported or exported for UNICEF's official use in accordance with the exemption from tax in Article II, Section 7 of the Convention of the Privileges and Immunities of the United Nations, 1946. In the event any governmental authority refuses to recognize this exemption from taxes, restrictions, duties or charges, the Contractor will immediately consult with UNICEF to determine a mutually acceptable procedure. The Contractor will provide full cooperation to UNICEF with regard to securing UNICEF's exemption from, or refund of amounts paid as, value-added taxes or taxes of a similar nature.

3.4 UNICEF will notify the Contractor of any dispute or discrepancy in the content or form of any invoice. With respect to disputes regarding only a portion of such invoice, UNICEF will pay the Contractor the amount of the undisputed portion in accordance with Article 3.5 below. UNICEF and the Contractor will consult in good faith to promptly resolve any dispute with respect to any invoice. Upon resolution of such dispute, any amounts that have not been charged in accordance with the Contract will be deducted from the invoice(s) in which they appear and UNICEF will pay any agreed remaining items in the invoice(s) in accordance with Article 3.5 within thirty (30) days after the final resolution of such dispute.

3.5 UNICEF will pay the uncontested amount of the Contractor's invoice within thirty (30) days of receiving both the invoice and the required supporting documents, as referred to in Article 3.2 above. The amount paid will reflect any discount(s) shown under the payment terms of the Contract. The Contractor will not be entitled to interest on any late payment or any sums payable under the Contract nor any accrued interest on payments

ANNEX A GENERAL TERMS AND CONDITIONS

withheld by UNICEF in connection with a dispute. Payment will not relieve the Contractor of its obligations under the Contract and will not be deemed to be acceptance by UNICEF of, or waiver of any of UNICEF's rights with regard to, the Contractor's performance.

3.6 Each invoice will confirm the Contractor's bank account details provided to UNICEF as part of the Contractor's registration process with UNICEF. All payments due to the Contractor under the Contract will be made by electronic funds transfer to that bank account. It is the Contractor's responsibility to ensure that the bank details supplied by it to UNICEF are up-to-date and accurate and notify UNICEF in writing by an authorized representative of the Contractor of any changes in bank details together with supporting documentation satisfactory to UNICEF.

3.7 The Contractor acknowledges and agrees that UNICEF may withhold payment in respect of any invoice if, in UNICEF's opinion, the Contractor has not performed in accordance with the terms and conditions of the Contract, or if the Contractor has not provided sufficient documentation in support of the invoice.

3.8 UNICEF will have the right to set off, against any amount or amounts due and payable by UNICEF to the Contractor under the Contract, any payment, indebtedness or other claim (including, without limitation, any overpayment made by UNICEF to the Contractor) owing by the Contractor to UNICEF under the Contract or under any other contract or agreement between the Parties. UNICEF will not be required to give the Contractor prior notice before exercising this right of set-off (such notice being waived by the Contractor). UNICEF will promptly notify the Contractor after it has exercised such right of set-off, explaining the reasons for such set-off, provided, however, that the failure to give such notification will not affect the validity of such set-off.

3.9 Each of the invoices paid by UNICEF may be subject to a post-payment audit by UNICEF's external and internal auditors or by other authorised agents of UNICEF, at any time during the term of the Contract and for three (3) years after the Contract terminates. UNICEF will be entitled to a refund from the Contractor of amounts such audit or audits determine were not in accordance with the Contract regardless of the reasons for such payments (including but not limited to the actions or inactions of UNICEF staff and other personnel).

4. Representations and Warranties; Indemnification; Insurance

Representations and Warranties

4.1 The Contractor represents and warrants that as of the effective date and throughout the term of the Contract: (a) the Contractor has the full authority and power to enter into the Contract and to perform its obligations under the Contract and the Contract is a legal, valid and binding obligation, enforceable against it in accordance with its terms; (b) all of the information it has previously provided to UNICEF, or that it provides to UNICEF during the term of the Contract, concerning the Contractor and the provision of the Services and the delivering of the Deliverables is true, correct, accurate and not misleading; (c) it is financially solvent and is able to provide the Services to UNICEF in accordance with the terms and conditions of the Contract; (d) it has, and will maintain throughout the term of the Contract, all rights, licenses, authority and resources necessary, as applicable, to provide the Services and deliver the Deliverables to UNICEF's satisfaction and to perform its obligations under the Contract; (e) the work product is and will be original to the Contractor and does not and will not infringe any copyright, trademark, patent or other proprietary right of any third party; and (f) except as otherwise expressly stated in the Contract, it has not and will not enter into any agreement or arrangement that restrains or restricts any person's rights to use, sell, dispose of or otherwise deal with any Deliverable or other work resulting from the Services. The Contractor will fulfill its commitments with the fullest regard to the interests of UNICEF and will refrain from any action which may adversely affect UNICEF or the United Nations.

4.2 The Contractor further represents and warrants, as of the effective date and throughout the term of the Contract, that it and its Personnel and sub-contractors will perform the Contract and provide the Services and Deliverables (a) in a professional and workmanlike manner; (b) with reasonable care and skill and in accordance with the highest professional standards accorded to professionals providing the same or substantially similar services in a same industry; (c) with priority equal to that given to the same or similar services for the Contractor's other clients; and (d) in accordance with all laws, ordinances, rules, and regulations bearing upon the performance of its obligations under the Contract and the provision of the Services and Deliverables.

4.3 The representations and warranties made by the Contractor in Articles 4.1 and 4.2 above are made to and are for the benefit of (a) each entity (if any) that makes a direct financial contribution to UNICEF to procure the Services and Deliverables; and (b) each Government or other entity (if any) that receives the direct benefit of the Services and Deliverables.

Indemnification

4.4 The Contractor will indemnify, hold and save harmless and defend, at its own expense, UNICEF, its

officials, employees, consultants and agents, each entity that makes a direct financial contribution to UNICEF to procure the Services and Deliverables and each Government or other entity that receives the direct benefit of the Services and Deliverables, from and against all suits, claims, demands, losses and liability of any nature or kind, including their costs and expenses, by any third party and arising out of the acts or omissions of the Contractor or its Personnel or sub-contractors in the performance of the Contract. This provision will extend to but not be limited to (a) claims and liability in the nature of workers' compensation, (b) product liability, and (c) any actions or claims pertaining to the alleged infringement of a copyright or other intellectual property rights or licenses, patent, design, trade-name or trade-mark arising in connection with the Deliverables or other liability arising out of the use of patented inventions or devices, copyrighted material or other intellectual property provided or licensed to UNICEF under the terms of the Contract or used by the Contractor, its Personnel or sub-contractors in the performance of the Contract.

4.5 UNICEF will report any such suits, proceedings, claims, demands, losses or liability to the Contractor within a reasonable period of time after having received actual notice. The Contractor will have sole control of the defence, settlement and compromise of any such suit, proceeding, claim or demand, except with respect to the assertion or defence of the privileges and immunities of UNICEF or any matter relating to UNICEF's privileges and immunities (including matters relating to UNICEF's relations with Host Governments), which as between the Contractor and UNICEF only UNICEF itself (or relevant Governmental entities) will assert and maintain. UNICEF will have the right, at its own expense, to be represented in any such suit, proceeding, claim or demand by independent counsel of its own choosing.

Insurance

4.6 The Contractor will comply with the following insurance requirements:

(a) The Contractor will have and maintain in effect with reputable insurers and in sufficient amounts, insurance against all of the Contractor's risks under the Contract (including, but not limited to, the risk of claims arising out of or related to the Contractor's performance of the Contract), including the following:

(i) Insurance against all risks in respect of its property and any equipment used for the performance of the Contract;

(ii) General liability insurance against all risks in respect of the Contract and claims arising out of the Contract in an adequate amount to cover all claims arising from or in connection with the Contractor's performance under the Contract;

(iii) All appropriate workers' compensation and employer's liability insurance, or its equivalent, with respect to its Personnel and sub-contractors to cover claims for death, bodily injury or damage to property arising from the performance of the Contract; and

(iv) Such other insurance as may be agreed upon in writing between UNICEF and the Contractor.

(b) The Contractor will maintain the insurance coverage referred to in Article 4.6(a) above during the term of the Contract and for a period after the Contract terminates extending to the end of any applicable limitations period with regard to claims against which the insurance is obtained.

(c) The Contractor will be responsible to fund all amounts within any policy deductible or retention.

(d) Except with regard to the insurance referred to in paragraph (a)(iii) above, the insurance policies for the Contractor's insurance required under this Article 4.6 will (i) name UNICEF as an additional insured; (ii) include a waiver by the insurer of any subrogation rights against UNICEF; and (iii) provide that UNICEF will receive thirty (30) days' written notice from the insurer prior to any cancellation or change of coverage.

(e) The Contractor will, upon request, provide UNICEF with satisfactory evidence of the insurance required under this Article 4.6.

(f) Compliance with the insurance requirements of the Contract will not limit the Contractor's liability either under the Contract or otherwise.

Liability

4.7 The Contractor will pay UNICEF promptly for all loss, destruction or damage to UNICEF's property caused by the Contractor's Personnel or sub-contractors in the performance of the Contract.

5. Intellectual Property and Other Proprietary Rights; Data Protection; Confidentiality

Intellectual Property and Other Proprietary Rights

ANNEX A GENERAL TERMS AND CONDITIONS

5.1 Unless otherwise expressly provided for in the Contract:

(a) Subject to paragraph (b) of this Article 5.1, UNICEF will be entitled to all intellectual property and other proprietary rights including but not limited to patents, copyrights and trademarks, with regard to products, processes, inventions, ideas, know-how, documents, data and other materials ("Contract Materials") that (i) the Contractor develops for UNICEF under the Contract and which bear a direct relation to the Contract or (ii) are produced, prepared or collected in consequence of, or during the course of, the performance of the Contract. The term "Contract Materials" includes, but is not limited to, all maps, drawings, photographs, plans, reports, recommendations, estimates, documents developed or received by, and all other data compiled by or received by, the Contractor under the Contract. The Contractor acknowledges and agrees that Contract Materials constitute works made for hire for UNICEF. Contract Materials will be treated as UNICEF's Confidential Information and will be delivered only to authorized UNICEF officials on expiry or termination of the Contract.

(b) UNICEF will not be entitled to, and will not claim any ownership interest in, any intellectual property or other proprietary rights of the Contractor that pre-existed the performance by the Contractor of its obligations under the Contract, or that the Contractor may develop or acquire, or may have developed or acquired, independently of the performance of its obligations under the Contract. The Contractor grants to UNICEF a perpetual, non-exclusive, royalty-free license to use such intellectual property or other proprietary rights solely for the purposes of and in accordance with the requirements of the Contract.

(c) At UNICEF's request, the Contractor will take all necessary steps, execute all necessary documents and generally assist in securing such proprietary rights and transferring them (or, in the case, intellectual property referred to in paragraph (b) above, licensing) them to UNICEF in compliance with the requirements of the applicable law and of the Contract.

Confidentiality

5.2 Confidential Information that is considered proprietary by either Party or that is delivered or disclosed by one Party ("Discloser") to the other Party ("Recipient") during the course of performance of the Contract or in connection with the subject matter of the Contract will be held in confidence by the Recipient. The Recipient will use the same care and discretion to avoid disclosure of the Discloser's Confidential Information as the Recipient uses for its own Confidential Information and will use the Discloser's Confidential Information solely for the purpose for which it was disclosed to the Recipient. The Recipient will not disclose the Discloser's Confidential Information to any other party:

(a) except to those of its Affiliates, employees, officials, representatives, agents and sub-contractors who have a need to know such Confidential Information for purposes of performing obligations under the Contract; or

(b) unless the Confidential Information (i) is obtained by the Recipient from a third party without restriction; (ii) is disclosed by the Discloser to a third party without any obligation of confidentiality; (iii) is known by the Recipient prior to disclosure by the Discloser; or (iv) at any time is developed by the Recipient completely independently of any disclosures under the Contract.

5.3 If the Contractor receives a request for disclosure of UNICEF's Confidential Information pursuant to any judicial or law enforcement process, before any such disclosure is made, the Contractor (a) will give UNICEF sufficient notice of such request in order to allow UNICEF to have a reasonable opportunity to secure the intervention of the relevant national government to establish protective measures or take such other action as may be appropriate and (b) will so advise the relevant authority that requested disclosure. UNICEF may disclose the Contractor's Confidential Information to the extent required pursuant to resolutions or regulations of its governing bodies.

5.4 The Contractor may not communicate at any time to any other person, Government or authority external to UNICEF, any information known to it by reason of its association with UNICEF that has not been made public, except with the prior written authorization of UNICEF; nor will the Contractor at any time use such information to private advantage.

Data Protection and Security

5.5 The Parties agree that, as between them, all UNICEF Data, together with all rights (including intellectual property and proprietary rights), title and interest to such UNICEF Data, will be the exclusive property of UNICEF, and the Contractor has a limited, nonexclusive license to access and use the UNICEF Data as provided in the Contract solely for the purpose of performing its obligations under the Contract. Except for the foregoing license, the Contractor will have no other rights, whether express or implied, in or to any UNICEF Data or its content.

5.6 The Contractor confirms that it has a data protection policy in place that meets all applicable data

protection standards and legal requirements and that it will apply such policy in the collection, storage, use, processing, retention and destruction of UNICEF Data. The Contractor will comply with any guidance or conditions on access and disclosure notified by UNICEF to Contractor in respect of UNICEF Data.

5.7 The Contractor will use its reasonable efforts to ensure the logical segregation of UNICEF Data from other information to the fullest extent possible. The Contractor will use safeguards and controls (such as administrative, technical, physical, procedural and security infrastructures, facilities, tools, technologies, practices and other protective measures) that are necessary and sufficient to meet the Contractor's confidentiality obligations in this Article 5 as they apply to UNICEF Data. At UNICEF's request, the Contractor will provide UNICEF with copies of the applicable policies and a description of the safeguards and controls that the Contractor uses to fulfil its obligations under this Article 5.7; provided that any such policies and description provided by the Contractor will be treated as the Contractor's Confidential Information under the Contract. UNICEF may assess the effectiveness of these safeguards, controls and protective measures and, at UNICEF's request, the Contractor will provide its full cooperation with any such assessment at no additional cost or expense to UNICEF. The Contractor will not, and will ensure that its Personnel will not, transfer, copy, remove or store UNICEF Data from a UNICEF location, network or system without the prior written approval of an authorized official of UNICEF.

5.8 Except as otherwise expressly stated in the Contract or with UNICEF's express prior written consent, the Contractor will not install any application or other software on any UNICEF device, network or system. The Contractor represents and warrants to UNICEF that the Services and Deliverables provided under the Contract will not contain any Disabling Code, and that UNICEF will not otherwise receive from the Contractor any Disabling Code in the performance of the Contract. Without prejudice to UNICEF's other rights and remedies, if a Disabling Code is identified, the Contractor, at its sole cost and expense, will take all steps necessary to: (a) restore and/or reconstruct any and all UNICEF Data lost by UNICEF and/or End Users as a result of Disabling Code; (b) furnish to UNICEF a corrected version of the Services without the presence of Disabling Codes; and (c) as needed, re-implement the Services.

5.9 In the event of any Security Incident, the Contractor will, as soon as possible following the Contractor's discovery of such Security Incident and at its sole cost and expense: (a) notify UNICEF of such Security Incident and of the Contractor's proposed remedial actions; (b) implement any and all necessary damage mitigation and remedial actions; and (c) as relevant, restore UNICEF's and, as directed by UNICEF, End Users' access to the Services. The Contractor will keep UNICEF reasonably informed of the progress of the Contractor's implementation of such damage mitigation and remedial actions. The Contractor, at its sole cost and expense, will cooperate fully with UNICEF's investigation of, remediation of, and/or response to any Security Incident. If the Contractor fails to resolve, to UNICEF's reasonable satisfaction, any such Security Incident, UNICEF can terminate the Contract with immediate effect.

Service Providers and Sub-Contractors

5.10 The Contractor will impose the same requirements relating to data protection and non-disclosure of Confidential Information, as are imposed upon the Contractor itself by this Article 5 of the Contract, on its service providers, subcontractors and other third parties and will remain responsible for compliance with such requirements by its service providers, subcontractors and other third parties.

End of Contract

5.11 Upon the expiry or earlier termination of the Contract, the Contractor will:

(a) return to UNICEF all of UNICEF's Confidential Information, including, but not limited to, UNICEF Data, or, at UNICEF's option, destroy all copies of such information held by the Contractor or its sub-contractors and confirm such destruction to UNICEF in writing; and

(b) will transfer to UNICEF all intellectual and other proprietary information in accordance with Article 5.1(a).

6. Termination; Force Majeure

Termination by Either Party for Material Breach

6.1 If one Party is in material breach of any of its obligations under the Contract, the other Party can give it written notice that within thirty (30) days of receiving such notice the breach must be remedied (if such breach is capable of remedy). If the breaching Party does not remedy the breach within the thirty (30) days' period or if the breach is not capable of remedy, the non-breaching Party can terminate the Contract. The termination will be effective thirty (30) days after the non-breaching Party gives the breaching Party written notice of termination. The initiation of conciliation or arbitral proceedings in accordance with Article 9 (Privileges and Immunities; Settlement of Disputes) below will not be grounds for termination of the Contract.

ANNEX A GENERAL TERMS AND CONDITIONS

Additional Termination Rights of UNICEF

6.2 In addition to the termination rights under Article 6.1 above, UNICEF can terminate the Contract with immediate effect upon delivery of a written notice of termination, without any liability for termination charges or any other liability of any kind:

- (a) in the circumstances described in, and in accordance with, Article 7 (Ethical Standards); or
- (b) if the Contractor breaches any of the provisions of Articles 5.2-5.11 (Confidentiality; Data Protection and Security); or
- (c) if the Contractor (i) is adjudged bankrupt, or is liquidated, or becomes insolvent, or applies for a moratorium or stay on any payment or repayment obligations, or applies to be declared insolvent, (ii) is granted a moratorium or a stay, or is declared insolvent, (iii) makes an assignment for the benefit of one or more of its creditors, (iv) has a receiver appointed on account of the insolvency of the Contractor, (v) offers a settlement in lieu of bankruptcy or receivership or (vi) has become, in UNICEF's reasonable judgment, subject to a materially adverse change in its financial condition that threatens to substantially affect the ability of the Contractor to perform any of its obligations under the Contract.

6.3 In addition to the termination rights under Article 6.1 and Article 6.2 above, UNICEF can terminate the Contract at any time by providing written notice to the Contractor in any case in which UNICEF's mandate applicable to the performance of the Contract or UNICEF's funding applicable to the Contract is curtailed or terminated, whether in whole or in part. UNICEF can also terminate the Contract on sixty (60) day's written notice to the Contractor without having to provide any justification.

6.4 As soon as it receives a notice of termination from UNICEF, the Contractor will take immediate steps to bring the performance of any obligations under the Contract to a close in a prompt and orderly manner, and in doing so, reduce expenses to a minimum, and will not undertake any further or additional commitments as of and following the date it receives the termination notice. In addition, the Contractor will take any other action that may be necessary, or that UNICEF may direct in writing, in order to minimise losses or protect and preserve any property, whether tangible or intangible, related to the Contract that is in the possession of the Contractor and in which UNICEF has or may be reasonably expected to acquire an interest.

6.5 If the Contract is terminated by either Party, the Contractor will immediately deliver to UNICEF any finished work which has not been delivered and accepted prior to the receipt of a notice of termination, together with any data, materials or work-in-process related specifically to the Contract. If UNICEF obtains the assistance of another party to continue the Services or complete any unfinished work, the Contractor will provide its reasonable cooperation to UNICEF and such party in the orderly migration of Services and transfer of any Contract-related data, materials and work-in-process. The Contractor will at the same time return to UNICEF all of UNICEF's Confidential Information and will transfer to UNICEF all intellectual and other proprietary information in accordance with Article 5.

6.6 If the Contract is terminated by either Party no payment will be due from UNICEF to the Contractor except for Services and Deliverables provided to UNICEF's satisfaction in accordance with the Contract, but only if such Services and Deliverables were required or requested before the Contractor's receipt of the notice of termination or, in the case of termination by the Contractor, the effective date of such termination. The Contractor will have no claim for any further payment beyond payments in accordance with this Article 6.6, but will remain liable to UNICEF for all loss or damages which may be suffered by UNICEF by reason of the Contractor's default (including but not limited to cost of the purchase and delivery of replacement or substitute Services or Deliverables).

6.7 The termination rights in this Article 6 are in addition to all other rights and remedies of UNICEF under the Contract.

Force Majeure

6.8 If one Party is rendered permanently unable, wholly, or in part, by reason of force majeure to perform its obligations under the Contract, the other Party may terminate the Contract on the same terms and conditions as are provided for in Article 6.1 above, except that the period of notice will be seven (7) days instead of thirty (30) days. "Force majeure" means any unforeseeable and irresistible events arising from causes beyond the control of the Parties, including acts of nature, any act of war (whether declared or not), invasion, revolution, insurrection, terrorism or other acts of a similar nature or force. "Force majeure" does not include (a) any event which is caused by the negligence or intentional action of a Party; (b) any event which a diligent party could reasonably have been expected to take into account and plan for at the time the Contract was entered into; (c) the insufficiency of funds, inability to make any payment required under the Contract, or any economic conditions, including but not limited to inflation, price escalations, or labour availability; or (d) any event

resulting from harsh conditions or logistical challenges for the Contractor (including civil unrest) associated with locations at which UNICEF is operating or is about to operate or is withdrawing from, or any event resulting from UNICEF's humanitarian, emergency, or similar response operations.

7. Ethical Standards

7.1 Without limiting the generality of Article 2 above, the Contractor will be responsible for the professional and technical competence of its Personnel including its employees and will select, for work under the Contract, reliable individuals who will perform effectively in the implementation of the Contract, respect the local laws and customs, and conform to a high standard of moral and ethical conduct.

7.2 (a) The Contractor represents and warrants that no official of UNICEF or of any United Nations System organisation has received from or on behalf of the Contractor, or will be offered by or on behalf of the Contractor, any direct or indirect benefit in connection with the Contract, including the award of the Contract to the Contractor. Such direct or indirect benefit includes, but is not limited to, any gifts, favours or hospitality.

(b) The Contractor represents and warrants that the following requirements with regard to former UNICEF officials have been complied with and will be complied with:

(i) During the one (1) year period after an official has separated from UNICEF, the Contractor may not make a direct or indirect offer of employment to that former UNICEF official if that former UNICEF official was, during the three years prior to separating from UNICEF, involved in any aspect of a UNICEF procurement process in which the Contractor has participated.

(ii) During the two (2) year period after an official has separated from UNICEF, that former official may not, directly or indirectly on behalf of the Contractor, communicate with UNICEF, or present to UNICEF, about any matters that were within such former official's responsibilities while at UNICEF.

(c) The Contractor further represents that, in respect of all aspects of the Contract (including the award of the Contract by UNICEF to the Contractor and the selection and awarding of sub-contracts by the Contractor), it has disclosed to UNICEF any situation that may constitute an actual or potential conflict of interest or could reasonably be perceived as a conflict of interest.

7.3 The Contractor further represents and warrants that neither it nor any of its Affiliates, or Personnel or directors, is subject to any sanction or temporary suspension imposed by any United Nations System organisation or other international inter-governmental organisation. The Contractor will immediately disclose to UNICEF if it or any of its Affiliates or Personnel or directors, becomes subject to any such sanction or temporary suspension during the term of the Contract.

7.4 The Contractor will (a) observe the highest standard of ethics; (b) use its best efforts to protect UNICEF against fraud, in the performance of the Contract; and (c) comply with the applicable provisions of UNICEF's Policy Prohibiting and Combatting Fraud and Corruption. In particular, the Contractor will not engage, and will ensure that its Personnel, agents and sub-contractors do not engage, in any corrupt, fraudulent, coercive, collusive or obstructive conduct as such terms are defined in UNICEF's Policy Prohibiting and Combatting Fraud and Corruption.

7.5 The Contractor will, during the term of the Contract, comply with (a) all laws, ordinances, rules and regulations bearing upon the performance of its obligations under the Contract and (b) the standards of conduct required under the UN Supplier Code of Conduct (available at the United Nations Global Marketplace website - www.ungm.org).

7.6 The Contractor further represents and warrants that neither it nor any of its Affiliates is engaged, directly or indirectly, (a) in any practice inconsistent with the rights set out in the Convention on the Rights of the Child, including Article 32, or the International Labour Organisation's Convention Concerning the Prohibition and Immediate Action for the Elimination of the Worst Forms of Child Labour, No. 182 (1999); or (b) in the manufacture, sale, distribution, or use of anti-personnel mines or components utilised in the manufacture of anti-personnel mines.

7.7 The Contractor represents and warrants that it has taken and will take all appropriate measures to prevent sexual exploitation or abuse of anyone by its Personnel including its employees or any persons engaged by the Contractor to perform any services under the Contract. For these purposes, sexual activity with any person less than eighteen years of age, regardless of any laws relating to consent, will constitute the sexual exploitation and abuse of such person. In addition, the Contractor represents and warrants that it has taken and will take all appropriate measures to prohibit its Personnel including its employees or other persons engaged by the Contractor, from exchanging any money, goods, services, or other things of value, for sexual favours or activities or from engaging in any sexual activities that are exploitive or degrading to any person. This provision constitutes an essential term of the Contract and any breach of this representation and warranty will

ANNEX A GENERAL TERMS AND CONDITIONS

entitle UNICEF to terminate the Contract immediately upon notice to the Contractor, without any liability for termination charges or any other liability of any kind.

7.8 The Contractor will inform UNICEF as soon as it becomes aware of any incident or report that is inconsistent with the undertakings and confirmations provided in this Article 7.

7.9 The Contractor acknowledges and agrees that each of the provisions in this Article 7 constitutes an essential term of the Contract.

(a) UNICEF will be entitled, in its sole discretion and at its sole choice, to suspend or terminate the Contract and any other contract between UNICEF and the Contractor with immediate effect upon written notice to the Contractor if: (i) UNICEF becomes aware of any incident or report that is inconsistent with, or the Contractor breaches any of, the undertakings and confirmations provided in this Article 7 or the equivalent provisions of any contract between UNICEF and the Contractor or any of the Contractor's Affiliates, or (ii) the Contractor or any of its Affiliates, or Personnel or directors becomes subject to any sanction or temporary suspension described in Article 7.3 during the term of the Contract.

(b) In the case of suspension, if the Contractor takes appropriate action to address the relevant incident or breach to UNICEF's satisfaction within the period stipulated in the notice of suspension, UNICEF may lift the suspension by written notice to the Contractor and the Contract and all other affected contracts will resume in accordance with their terms. If, however, UNICEF is not satisfied that the matters are being adequately addressed by the Contractor, UNICEF may at any time, exercise its right to terminate the Contract and any other contract between UNICEF and the Contractor.

(c) Any suspension or termination under this Article 7 will be without any liability for termination or other charges or any other liability of any kind.

8. Full Cooperation with Audits And Investigations

8.1 From time to time, UNICEF may conduct inspections, post-payment audits or investigations relating to any aspect of the Contract including but not limited to the award of the Contract, the way in which the Contract operates or operated, and the Parties' performance of the Contract generally and including but not limited to the Contractor's compliance with the provisions of Article 7 above. The Contractor will provide its full and timely cooperation with any such inspections, post-payment audits or investigations, including (but not limited to) making its Personnel and any relevant data and documentation available for the purposes of such inspections, post-payment audits or investigations, at reasonable times and on reasonable conditions, and granting UNICEF and those undertaking such inspections, post-payment audits or investigations access to the Contractor's premises at reasonable times and on reasonable conditions in connection with making its Personnel and any relevant data and documentation available. The Contractor will require its sub-contractors and its agents, including, but not limited to, the Contractor's attorneys, accountants or other advisers, to provide reasonable cooperation with any inspections, post-payment audits or investigations carried out by UNICEF.

9. Privileges and Immunities; Settlement of Disputes

9.1 Nothing in or related to the Contract will be deemed a waiver, express or implied, deliberate or inadvertent, of any of the privileges and immunities of the United Nations, including UNICEF and its subsidiary organs, under the Convention on the Privileges and Immunities of the United Nations, 1946, or otherwise.

9.2 The terms of the Contract will be interpreted and applied without application of any system of national or sub-national law.

9.3 The Parties will use their best efforts to settle amicably any dispute, controversy or claim arising out of, or relating to the Contract. Where the Parties wish to seek such an amicable settlement through conciliation, the conciliation will take place in accordance with the UNCITRAL Conciliation Rules then in force, or according to such other procedure as may be agreed between the Parties. Any dispute, controversy or claim between the Parties arising out of the Contract which is not resolved within ninety (90) days after one Party receives a request from the other Party for amicable settlement can be referred by either Party to arbitration. The arbitration will take place in accordance with the UNCITRAL Arbitration Rules then in force. The venue of the arbitration will be New York, NY, USA. The decisions of the arbitral tribunal will be based on general principles of international commercial law. The arbitral tribunal will have no authority to award punitive damages. In addition, the arbitral tribunal will have no authority to award interest in excess of the London Inter-Bank Offered Rate (LIBOR) then prevailing and any such interest will be simple interest only. The Parties will be bound by any arbitration award rendered as a result of such arbitration as the final adjudication of any such controversy, claim or dispute.

10. Notices

10.1 Any notice, request or consent required or permitted to be given or made pursuant to the Contract will be in writing, and addressed to the persons listed in the Contract for the delivery of notices, requests or consents. Notices, requests or consents will be delivered in person, by registered mail, or by confirmed email transmission. Notices, requests or consents will be deemed received upon delivery (if delivered in person), upon signature of receipt (if delivered by registered mail) or twenty-four (24) hours after confirmation of receipt is sent from the addressee's email address (if delivered by confirmed email transmission).

10.2 Any notice, document or receipt issued in connection with the Contract must be consistent with the terms and conditions of the Contract and, in case of any ambiguity, discrepancy or inconsistency, the terms and conditions of the Contract will prevail.

10.3 All documents that comprise the Contract, and all documents, notices and receipts issued or provided pursuant to or in connection with the Contract, will be deemed to include, and will be interpreted and applied consistently with, the provisions of Article 9 (Privileges and Immunities; Settlement of Disputes).

11. Other Provisions

11.1 The Contractor acknowledges UNICEF's commitment to transparency as outlined in UNICEF's Information Disclosure Policy and confirms that it consents to UNICEF's public disclosure of the terms of the Contract should UNICEF so determine and by whatever means UNICEF determines.

11.2 The failure of one Party to object to or take affirmative action with respect to any conduct of the other Party which is in violation of the terms of the Contract will not constitute and will not be construed to be a waiver of the violation or breach, or of any future violation, breach or wrongful conduct.

11.3 The Contractor will be considered as having the legal status of an independent contractor as regards UNICEF. Nothing contained in the Contract will be construed as making the Parties principal and agent or joint venturers.

11.4 The Contractor will not, without the prior written consent of UNICEF, assign, transfer, pledge or make other disposition of the Contract, or of any part of the Contract, or of any of the Contractor's rights or obligations under the Contract.

11.5 No grant of time to the Contractor to cure a default under the Contract, nor any delay or failure by UNICEF to exercise any other right or remedy available to UNICEF under the Contract, will be deemed to prejudice any rights or remedies available to UNICEF under the Contract or constitute a waiver of any rights or remedies available to UNICEF under the Contract.

11.6 The Contractor will not seek or file any lien, attachment or other encumbrance against any monies due or to become due under the Contract, and will not permit any other person to do so. It will immediately remove or obtain the removal of any lien, attachment or other encumbrance that is secured against any monies due or to become due under the Contract.

11.7 The Contractor will not advertise or otherwise make public for purposes of commercial advantage or goodwill that it has a contractual relationship with UNICEF or the United Nations. Except as regards references to the name of UNICEF for the purposes of annual reports or communication between the Parties and between the Contractor and its Personnel and sub-contractors, the Contractor will not, in any manner whatsoever use the name, emblem or official seal of UNICEF or the United Nations, or any abbreviation of the name of the United Nations, in connection with its business or otherwise without the prior written permission of UNICEF.

11.8 The Contract may be translated into languages other than English. The translated version of the Contract is for convenience only, and the English language version will govern in all circumstances.

11.9 No modification or change in the Contract, and no waiver of any of its provisions, nor any additional contractual relationship of any kind with the Contractor will be valid and enforceable against UNICEF unless set out in a written amendment to the Contract signed by an authorised official of UNICEF.

11.10 The provisions of Articles 2.14, 3.8, 3.9, 4, 5, 7, 8, 9, 11.1, 11.2 and 11.7 will survive provision of the Services and delivery of the Deliverables and the expiry or earlier termination of the Contract.

Terms of Reference

UNICEF MOLDOVA

STATEMENT OF WORK

Washrooms renovation works, Health Centers from Cahul and Ungheni, Moldova

BACKGROUND

- 1.1. UNICEF Moldova is supporting the Ungheni and Cahul focal regions to improve the quality and access to local public services for children and adolescents through capacity building for healthcare workers at the Primary Health Care Centers and development of the Early Childhood Intervention (ECI) services. As such, 2 dedicated local teams of specialists on ECI were created and able to perform assessments on young children's development, including refugees. The ECI Centers are established in the Health Centers (HC) from Cahul and Ungheni, respectively. However, to ensure a healthier start in life and keep children thriving, access to clean water, basic toilets, and good hygiene practices are pivotal. Therefore, renovation works of the washrooms are needed in both Health Centers.
- 1.2. To that aim, UNICEF Moldova is interested to contract a company which will renovate one washroom from HC Cahul and two double washrooms from HC Ungheni as detailed in the Scope of the Work below and the technical documents included at Annex E.

2.0 DEFINITION

- 2.0 **Renovation** of the washrooms which implies the activities mentioned in the Scope of Work below shall be completed in two (2) months counted from the signature of the contract.

3.0 SCOPE OF WORK

- 3.1 **Objective:** The objective of these Terms of Reference is to perform a bidding exercise to identify a suitable Contractor to execute the Works described in the Bills of Quantities attached at Annex E within the agreed quality, budget and timeline. The general aim of the Project is to improve access to children, (including refugees) to Water, Sanitation and Hygiene (WASH) facilities in the HC from Cahul and Ungheni.
- 3.2 **Nature of works and location:** This Project includes **renovation** of three washrooms located in Cahul HC (one washroom) and Ungheni HC (two double washrooms).
The following description of the scope of works intends to convey a general understanding of the work required. Please note that the items mentioned below are generic and will vary based on the specific needs:
- 3.3 **Organization of project into phases:** This is a one-off project.
- 3.4 **Division of project into lots:** this is a one-lot project
- 3.5 **General specifications:** The Works will be carried out in accordance with the Drawings, Bill of Quantities and Technical Specifications provided under Annex E: Technical Documents and in accordance with all construction standards applicable in Moldova.
- 3.6 **Greening and accessibility:** All construction and rehabilitation works implemented directly or indirectly by UNICEF shall be in line with the Organization's commitments towards Accessible Buildings and achieving Climate Neutrality by 2020, as per [PROCEDURE/DFAM/2020/001](#) on Eco-efficiency and Inclusive Access in UNICEF Premises and Operations, [CF/EXD/2017-004](#) on Accessibility in UNICEF's Programme-Relegated Construction, and Decision Memo: UNICEF Climate Neutral Strategy, 26 May 2015.
- 3.7 **Other Considerations:** N/A

4.0 EXPECTED DELIVERABLES AND TIMEFRAME

- 4.1 The timely completion of these construction Works is of utmost importance for UNICEF.

- 4.2 The Intended Final Completion Date should be no later than 2 calendar months from the **Start Date, no later than 30.11.2023**. Upon UNICEF's acceptance of Works, the Certificate of Final Completion will be issued.
- 4.3 The payment will be effected in full by UNICEF in one transfer upon full delivery and acceptance of services. The invoice should have attached a copy of the works report. The reports shall bear the signatures of the Construction Company's site Manager, Local public Authority site supervisor on site and the UNICEF Construction Engineer.

Table 1: Deliverables and Timeframe

Deliverable #	Scope of deliverable	Timeframe
1	Complete renovation works as per the BoQ, final completion and contract closure	By end of 2 nd month

5.0 PROJECT MANAGEMENT

5.1 Project Management and Coordination

- UNICEF will oversee the Works and the administration of the Contract, including the certification of payments through an appointed Project Management, or any other competent person, entity or firm appointed by UNICEF and notified to the Contractor, to act in replacement of the Project Manager.
- UNICEF will supervise and inspect the Works during its execution through its Project Manager, or its representative. The Project Manager, or its representative, will provide instructions and clarify technical queries during the execution of Works in consultation with UNICEF.
- UNICEF, through its Project Manager or its representative, will regularly check the progress of Works and notify the Contractor of any defects that are found. Such checking shall not affect the Selected Contractor's responsibilities.
- If the Selected Contractor has not corrected a defect within the time agreed with UNICEF's Project Manager or its representative, the Contractor will be liable for Liquidated Damages.
- Communications between parties shall be valid only when in writing. Notice shall be valid only when it is delivered.

5.2 Management Meetings

- Either UNICEF's Project Manager, its representative or the Contractor may require the others to attend a management meeting. The business of a management meeting shall be to review the plans for remaining Works and to deal with matters raised under the procedure for "Delays and Extension of time" sets out under UNICEF Contract for Construction.
- UNICEF's Project Manager or its representative shall record the meetings and provide copies of the record to those attending the meeting and to UNICEF, including action points and responsible for each action point.

5.3 Payment Certificates

- The Bill of Quantities is used to calculate the Contract Price for each Deliverable. The Contractor will be paid for each deliverable accepted by UNICEF and following the price to each Deliverable agreed in the Contract.
- UNICEF will certify acceptance of partial, substantial, and final Works through its Project Management, or its representative. No payments will be processed prior to a written certificate of its satisfactory acceptance. Payments will be issued within a period defined in the Contract and following UNICEF's procedures.

ANNEX C: QUOTATION FORMS

The following Annexes and information there within are considered an integral part of this submission and must be provided for the Quotation to be considered. The information should be provided according to the sample format.

Form 1: Potential Bidder General Information

Bidder's General Information		
1	Company legal name	
2	Company founded year	
3	Company tax number (IDNO)	
4	Company license number and expiry date	
5	Company legal address	
6	Company office address	
7	Company contact number	
8	Company official email address	

Form 2: Potential Bidder's Contact Details,

Name and Title of Contact Person	_____
Address of Contact Person	_____
Telephone/Cell number of Contact Person	_____
Email of Contact Person	_____

Form 3: Staff Qualification and Company Experience

Qualifications and experience of key management and technical personnel proposed for this Project. Substitution of staff during Project implementation shall be subject to the approval of UNICEF. (Key Personnel of all sub-Contractors must also be listed along with the name of the sub-Contracting Companies). A detailed organization chart of the company, including the location and staffing of existing offices must also be attached to the offer.

Construction Management Staff		
A. Key Professionals		
Name	Position	Task
B. Support Staff		
Name	Position	Task

Company Experience and References			
<p>Contractor's Project Track Record for The Last Three (3) Years. <i>Include only projects where the company was the main/prime contractor</i> <i>Provide proof e.g attach completion certificates and or copies of contract</i> <i>Include only projects concerning building construction and /or rehabilitation</i> <i>Include contact email and telephone number of the project owner</i></p>			
Project Description	Contract Value (USD)	Project Duration [From-To]	Name & Contact Details of Client's representative

<p>Total Value of Projects Completed Each Year, For the Last Three (3) Years. <i>Include only projects where the company was the main/prime contractor</i> <i>Provide proof e.g attach completion certificates</i></p>		
Year	Countries of Operation	Total Value of Works
2022		

2021		
2020		
Total Contract Value for The Three Years (USD)		

Form 4: Works in hand & their Financial Value

Works in Hand				
Employer name & contact details	Description of Works/Services	Start date	End date	Amount
			Total:	

Form 5: Litigations

Information on any current litigation in which the Firm(s) is involved.

Other Party(ies)	Cause of Dispute	Amount Involved

Form 6: Proposed Project Implementation Plan

The proposed Project Implementation Plan of Works and schedule of activities must be submitted with this Technical Proposal. The work plan and schedule should be prepared in detail to the extent possible and include time allocated to sites- and district-level periodic progress review meetings and preparation of agreed progress reports.

The Potential Bidder may be asked to provide clarification or present the Proposed Plan to UNICEF as part of the Proposal evaluation process. The Project Implementation Plan submitted by the Selected Contractor and accepted by UNICEF will be part of the agreement signed with the Selected Contractor. Penalties for delays will be strictly enforced as per the General Terms and Conditions.

The Proposed Implementation plan shall include:
- implementation methods,

- quality control strategy,
- schedule for all activities in a bar chart format, personnel plan in line with scheduled Deliverables and payment,
- analysis of anticipated Project risks, and their approach to mitigate and control such risks,
- proposed approach to mitigate negative social and environmental impact on local community by the Project, approach to address labor's rights and their health and safety

ANNEX D: FINANCIAL PROPOSAL FORMS

Form 7: Financial Proposal Letter

Date: _____

To: UNICEF Moldova, 131, 31 August 1989, MD-2012, Chisinau, Moldova

Dear Madam/Sir,

We, the undersigned, offer to provide the washrooms renovation works in Cahul and Ungheni Health Centers as specified in the Annexes B and E following your Request for Quotations dated 04 September 2023, and our Proposal for the subject RFQ.

Our attached Financial Proposal is for the sum of (-----
-----amount in figures and words). This amount does not include VAT or other taxes.

Our Financial Proposal shall be binding on us subject to the modifications resulting from Contract negotiations, up to the expiration of the validity of the Proposal.

We understand that you are not bound to accept any Proposal you receive.

Yours sincerely,

Authorized Signature:

Name and Title of Signatory:

Name of Construction Company

Address:

Form 8: Summary of Financial Proposal (from BOQ)

Nr	Project Name	Location	Total Value (MDL)
1	Washroom renovation, Ungheni Health Center (2 double washrooms)	Ungheni	
2	Washroom renovation, Cahul Health Center (one washroom)	Cahul	

Notes:

- UNICEF will assume that the Potential Bidder has factored in its offer all causes that may influence the prices.
- All prices are inclusive of all fees, sub-Contractor fees, documentation reproduction, legal fees, contingencies, and administrative fees, all taxes, or any other fees necessary to the Potential Bidder to achieve the Objective of the RFQ.
- All amounts should be quoted in MDL, without VAT or other taxes.
- The Selected Contractor shall be paid only upon UNICEF acceptance of the work or deliverable.
- Inform the Bank, branch, and account information. Indicate names of persons operating the agency account. All payment will be done through bank transfer.
- The Potential Bidder may suggest the alternative payment schedule (the manner in which payment requested), with justification of each installment with the Deliverables UNICEF will receive against each installment required.
- In case, advance payment is requested, the Selected Contractor should provide an unconditional guarantee issued by a bank on behalf of the Selected Contractor and in favor of UNICEF to guarantee either submission of deliverables according to the Contract, or to refund the advance to UNICEF in case of default by the Selected Contractor. The Selected Contractor must bear any charges for such guarantee.

ANNEX E
Technical documents

English Version, Cahul PHCF

**TECHNICAL SPECIFICATIONS
FOR PRICE QUOTATION**

- 1. Name of the state beneficiary Cahul Health Center PHCF**
- 2. Organizer of the procurement procedure: UNICEF Moldova, for Cahul Health Center PHCF**
- 3.**
- 4. Object of procurement: Renovation of one washroom at Cahul Health Center PHCF**

No	Standard symbol and resource code	Name of works	Unit of measure	Volume
1	2	3	4	5
		1. 3rd floor toilet block repairs		
1	RpCM33A	Dismantling the plates of floor tiles, ceramics, and pottery	m2	52.52
2	RpCO56A	Dismantling of the wooden carpeting (doors, windows, shutter, rolls, cases, masks, etc.)	m2	4.41
3	RpCB18F	Demolishing the old concrete with mechanic means, simple concrete	m3	1.65
4	CK25A	Installation of PVC profiles single-leaf doors including the fittings and necessary accessories for them, with frame area up to 7 m ² inclusively, in any type of masonry, in buildings with height of up to 35 m inclusively	m2	2.10
5	CK23C	Plastic windows with one or more leafs in buildings up to and including 35 m high, with a frame area of more than 2.5 square metres. Note: 5-chamber PVC windows with thermal insulation, profile width – 50 mm, Low-E double glazing, 1.5 mm U galvanised steel frame, double opening, soft closing and opening hinges, including insect screen and Air-Box Comfort vent. Note: (price not specified – provided by the beneficiary)	m2	10.19
6	CK26A	Sills assembled at the windows from plastic, for windows and doors Small materials (sills) = 1.02	m	5.75

7	CK26D	Sills assembled at the windows or doors from aluminum	m	5.75
8	CK26C	Sills assembled at the windows or doors from plastic	m	5.75
9	CF54B	Wall boarding	m2	86.16

1	2	3	4	5
		with 12.5 mm thick plasterboard mounted on galvanized steel studs structure: on flat surfaces, including boarding of door and window slopes (moisture-resistant plasterboard)		
10	market price	Mineral fibre insulation material in rolls, 20 cm thick	m2	3.00
11	CN53A	Coating the internal surfaces of the walls and ceilings	m2	86.16
12	CI06C	Glazed, unglazed, matt or glossy earthenware tiles of the same colour and design, ranging in size from 15 x 15 cm to 30 x 30 cm, laid on flat walls and floor surfaces, including window sills and slopes, in alternating pattern, in rooms larger than 10 square metres, laid on tile adhesive (colour, shape, size of tiles to be agreed with the beneficiary).	m2	43.08
13	CF57A	Manual application of the gypsum-based putty "Eurofin" thickness 1,0 mm on the ceilings', walls' and columns' surfaces.	m2	43.08
14	CF56A	Manual application of the putty for interior works "Mesterul Manole" thickness 0,5 mm on the surfaces of walls, columns, and ceilings	m2	43.08
15	CN53A	Coating the internal surfaces of the walls and ceilings	m2	43.08
16	CN06A	Interior painting with vinyl copolymer-based paint in water emulsion, applied by hand in 2 coats on existing plaster	m2	43.08
17	CK29F	Suspended ceiling from pre-manufactured panels "Armstrong", including the grid-system	m2	16.71
18	RpSC06A	Dismantling a closet reservoir of pottery, completely equipped	pcs	1.00
19	RpSB01A	Dismantling the tubes and the connecting pieces from cast iron, for sewerage, with diameter of 50 mm	m	4.00
20	SA14B	Polyfusion welded plastic piping, for industrial structures,	m	7.00

1	2	3	4	5
		diameter 20 mm		
21	SB08C	Plastic sewer pipe , combined with rubber case, surface-mounted or buried under the floor, having a diameter of 50 mm	m	6.00
22	SB08E	Plastic sewer pipe, combined with rubber case, surface-mounted or buried under the floor, having a diameter of 110 mm	m	1.00
23	SB10E	Plastic sewer pipe (one branch) with rubber gasket, diameter 110 mm	pcs	2.00
24	SB10C	Plastic sewer pipe (one branch) with rubber gasket, diameter 50 mm.	pcs	7.00
25	CN53A	Coating the internal surfaces of the walls and ceilings	m2	16.71
26	CG56A	Blanket from self-levelling mixture "Nivelir": thickness 10mm Small materials (expanded polystyrene for deformation joints, cloth, controls) = 1.005	m2	16.71
27	IzF31A	Waterproofing of concrete surfaces (vertical, horizontal, including ceilings) with Penetron mixture – 2 layers: smooth surface (Hydroisol)	m2	24.92
28	CG17D	Flooring from ceramic plates including the support layer from adhesive mortar, executed on areas wider than 16 m2	m2	16.71
29	SD01A	Service tap, simple or double with adapter, regardless of the closing modality, having the diameter 3/8" - 1/2" Subsidiary materials (hemp seal, linseed oil, minium lead primer, etc.)=1,005	pcs	1.00
30	SD04A	Monobloc lever mixer tap for washbasin or sink, any closing mode, including for people with disabilities, with 1/2" diameter (no price – provided by the beneficiary)	pcs	1.00

1	2	3	4	5
31	SC04A	Washbasin made of semi-porcelain, sanitary porcelain, etc. including for people with disabilities, with plastic drain pipe, mounted on brackets fixed on brick or concrete walls (no price – provided by the beneficiary) Small materials (wooden dowel, gypsum, etc.) = 1.02	pcs	1.00
32	RpID10A	Installation of shut-off valves (valves under the sink)	pcs	3.00
33	SC07A	S-Trap toilet bowl, fully equipped, made of semi-porcelain, sanitary porcelain, etc., including for people with disabilities, floor-standing, with water tank mounted at height or half-height (no price – provided by the beneficiary) Subsidiary materials (wooden dowels, gypsum, screws, Codez adhesive, diclorethane, etc.) = 1.05	pcs	1.00
34	CH06A	Metal handrail for people with disabilities, mounted on supports 15 cm high, placed at a distance of 1 1.2 m, equipped with welded washers, fixed on a brick wall or concrete parapet, made of steel pipe D=1 1/4" and rolled steel, straight, (stainless steel support bar for people with disabilities)	m	2.50
35	RpED08A	Installation of copper electrical cables with PVC insulation, with increased flame propagation resistance, for voltages of 0.6/1 kV, symbol CYYF, surface-mounted, with cross-section of 2x1.5 mm ² . Subsidiary materials (clamps, shoes, wire, insulation tape) of the value of the materials specified=1,05	m	25.00
36	RpED09A	Installation of copper electrical cables with PVC insulation, with increased flame propagation resistance, for voltages of 0.6/1 kV, symbol CYYF, surface-mounted, with cross-section of 3x1,5-3x10 mm ² (LS 3x1,5) Subsidiary materials (clamps, shoes, wire, insulation tape) of the value of the materials specified=1,05	m	32.00
37	RpEE01A	Installation of 10-25A single-pole or double-pole circuit breakers of conventional design, sealed or enclosed in aminoplast, bakelite, metal or porcelain enclosures, mounted buried or surface-mounted on wooden or plastic dowels, connected to copper or aluminium conductors.	pcs	2.00

1	2	3	4	5
38	RpEE03A	Assembling bipolar sockets in normal constructions from bakelite or amino-plastic, simple, double, water-proof construction, seals, metallic or similar seals, assembled under coating or visibly on the wood or plastic gimlets	pcs	2.00
39	RpEF01B	Installation of lighting fixtures, ceiling or wall mounted, having all component parts Subsidiary materials (insulation tape, dowels, etc.)=1.04	pcs	5.00
40	RpIB11A	Dismantling the position-based radiators to be liquidated	m2	1.00
41	RpSA01B	Removal of existing 1 1/4"-2" diameter galvanised steel pipe for installations, located inside the building in the ground	m	12.00
42	SA14C	Pipe of plastic material, combined through poly-fusion welding, in industrial constructions, having the diameter of 25 mm	m	12.00
43	SA35A	Ductile iron fittings screwed onto steel pipes for galvanised installations, on columns for indoor hydrants, pipe diameters up to 1".Subsidiary materials (hemp seal, minium lead primer, etc.)=1,01	pcs	4.00
44	ID01A	Tap with valve with double control (supply or return) for central heating installations, having the nominal diameter 3/8" -1/2"	pcs	4.00
45	IB06A	Steel radiators, one-piece, length 1000 mm (no price – provided by the beneficiary)	pcs	2.00

**CAIET DE SARCINI
PENTRU CEREREA OFERTEI DE PREȚ**

1. Denumirea beneficiarului de stat: **IMSP Centrul de Sanatate Cahul**
2. Organizatorul procedurii de achizitie: **UNICEF Moldova, pentru IMSP CS Cahul**
3. Obiectul achizitiilor: **Lucrari de reparatie la blocul sanitar al IMSP Centrul de Sanatate Cahul**

№ crt.	Simbol norme și Cod resurse	Denumire lucrărilor	Unitate a de masura	Volum
1	2	3	4	5
1. Reparatii blocuri sanitare et.3				
1	RpCM33A	Demontarea placajelor din faianta, gresie, ceramica	m2	52,52
2	RpCO56A	Demontari: timplarie din lemn (usi, ferestre, obloane, cutii, rulou, masti, etc.)	m2	4,41
3	RpCB18F	Demolarea betoanelor vechi cu mijloace mecanice, beton simplu	m3	1,65
4	CK25A	Usi confectionate din profiluri din mase plastice inclusiv armaturile si accesoriile necesare usilor montate in zidarie de orice natura la constructii cu inaltimea pina la 35 m inclusiv, intr-un canat, cu suprafata tocului pina la 7 mp inclusiv	m2	2,10
5	CK23C	Ferestre din mase plastice cu unul sau mai multe canaturi la constructii cu inaltimei pina la 35 m inclusiv, avind suprafata tocului peste 2,5 mp Nota Ferestre PVC 5 camere de izolatie termica,, latimea profilului de 50mm, geam termopan Low-E, armatura din otel zincat U 1.5mm, dubla deschidere, feroniera cu rezistenta inalta la inchidere - deschidere , inclusiv plasa contra insectelor si Supapa de aerisire Air-Box Comfort Nota: (fara pret - asigurate de beneficiar)	m2	10,19
6	CK26A	Glafuri montate la ferestre din mase plastice, pentru ferestre si usi Materiale marunte (dopuri)=1,02	m	5,75
7	CK26D	Pervazuri montate la ferestre sau usi din aluminiu	m	5,75

8	CK26C	Pervazuri montate la ferestre sau usi din mase plastice	m	5,75
9	CF54B	Placarea peretilor cu placi din ghips-carton,	m2	86,16

1	2	3	4	5
		grosime 12,5 mm, montati pe structura din profil zincat: pe suprafete plane, inclusiv glafurile usilor si ferestrelor (Placa rezistenta la umezeala)		
10	pret de piata	Materiale izolante din fibre minerale in rulouri gr 20 cm	m2	3,00
11	CN53A	Grunduirea suprafetelor interioare a peretilor si tavanelor.	m2	86,16
12	CI06C	Placaj din fainata smaltuita, nesmaltuita, mata sau lucioasa cu placi de aceeasi culoare si format cu dimensiuni de la 15 x 15 cm pina la 30 x 30 cm, executate pe suprafete plane la pereti si stilpi, inclusiv glafurile si muchiile, cu rosturi alternante, in incaperi cu suprafata mai mare de 10 mp, fixate cu adeziv pentru montarea placajelor (culoarea , forma, dimensiunea gresiei se coordoneaza cu beneficiarul)	m2	43,08
13	CF57A	Aplicarea manuala a chitului pe baza de ipsos "Eurofin" grosime 1,0 mm pe suprafetele peretilor, coloanelor si tavanelor	m2	43,08
14	CF56A	Aplicarea manuala a chitului pentru lucrari la interior "Mesterul Manole" grosime 0,5 mm pe suprafetele peretilor, coloanelor si tavanelor	m2	43,08
15	CN53A	Grunduirea suprafetelor interioare a peretilor si tavanelor	m2	43,08
16	CN06A	Vopsitorii interioare cu vopsea pe baza de copolimeri vinilici in emulsie apoasa, aplicate in 2 straturi pe glet existent, executate manual	m2	43,08
17	CK29F	Tavane suspendate din panouri prefabricate "Armstrong", inclusiv sistemul-grila	m2	16,71
18	RpSC06A	Demontarea unui vas de closet din faianta, complet echipat	buc	1,00

19	RpSB01A	Demontarea tuburilor si pieselor de legatura fasonate din fonta, pentru canalizare, cu diametrul de 50 mm	m	4,00
20	SA14B	Teava din material plastic imbinata prin sudura prin polifuziune, la constructii	m	7,00

1	2	3	4	5
		industriale, avind diametrul de 20 mm		
21	SB08C	Teava din material plastic pentru canalizare, imbinata cu garnitura de cauciuc, montata aparent sau ingropat sub pardoseala, avind diametrul de 50 mm	m	6,00
22	SB08E	Teava din material plastic pentru canalizare, imbinata cu garnitura de cauciuc, montata aparent sau ingropat sub pardoseala, avind diametrul de 110 mm	m	1,00
23	SB10E	Piesa de legatura (ramificatie simpla) din material plastic pentru canalizare, imbinata cu garnitura de cauciuc, avind diametrul de 110 mm	buc	2,00
24	SB10C	Piesa de legatura (ramificatie simpla) din material plastic pentru canalizare, imbinata cu garnitura de cauciuc, avind diametrul de 50 mm	buc	7,00
25	CN53A	Grunduirea suprafetelor interioare a peretilor si tavanelor	m2	16,71
26	CG56A	Sapa din amestec de autonivelare "Nivelir": grosime 10mm Material marunt (polistiren expandat pentru rosturi de deformatie, cirpe, martori)=1,005	m2	16,71
27	IzF31A	Hidroizolarea suprafetelor din beton (verticale, orizontale, inclusiv tavane) cu amestec "Penetron" - 2 straturi: suprafata neteda (Ghidroizol)	m2	24,92
28	CG17D	Pardoseli din placi de gresie ceramica inclusiv stratul suport din mortar adeziv, executate pe suprafete: mai mari de 16 m2	m2	16,71
29	SD01A	Robinet de serviciu, simplu sau dublu cu racord, indiferent de modul de inchidere, avind diametrul de 3/8" - 1/2" Material marunt (cinepa fuior, ulei de in, grund miniu de plumb etc)=1,005	buc	1,00

30	SD04A	Baterie amestecatoare cu brat basculant stativa pentru lavoar sau spalator, indiferent de modul de inchidere, inclusiv pentru handicapati, avind diametrul de 1/2"(fara pret - asigurate de catre beneficiar)	buc	1,00
----	-------	---	-----	------

1	2	3	4	5
31	SC04A	Lavoar din semiportelan, portelan sanitar etc. inclusiv pentru handicapati, avind teava de scurgere din material plastic, montat pe console fixate pe pereti din zidarie de caramida sau b.c.a.(fara pret -asigurat de catre beneficiar) Material marunt (codez, diblu lemn, ipsos, etc)=1,02	buc	1,00
32	RpID10A	Montarea robinetului de retinere, (robineti sub lavuar)	buc	3,00
33	SC07A	Vas pentru closet, complet echipat, din semiportelan, portelan sanitar etc. inclusiv pentru handicapati, asezat pe pardoseala, cu rezervorul de apa montat la inaltime sau semiinaltime, avind sifonul interior tip S (fara pret - asigurate de catre beneficiar) Material marunt (dibluri lemn, ipsos, holtsuruburi, codez, dicloretan, etc.)=1,05	buc	1,00
34	CH06A	Mina curenta metalica montata pe suporti de 15 cm inaltime, asezati la distante de 1.1,2 m prevazuti cu rondele sudate, fixata in zid de caramida sau parapet de beton, confectionata din teava din otel D=1 1/4" si otel laminat, dreapta ,(bara suport din inox pentru persoane cu dezabilitati)	m	2,50
35	RpED08A	Montarea cablurilor electrice din cupru, cu izolatie din PVC, cu rezistenta marita la propagarea flacarilor, pentru tensiuni de 0,6/1 kV, simbol CYYF, montate aparent, avind sectiunea de 2x1,5 mmp Materiale marunte (cleme, papuci, sirma, banda izol.) din val.mat.explicitate=1,05	m	25,00
36	RpED09A	Montarea cablurilor electrice din cupru, cu izolatie din PVC, cu rezistenta marita la propagarea flacarilor, pentru tensiuni de 0,6/1 kV, simbol CYYF, montate aparent, avind sectiunea de 3x1,5-3x10 mmp (LS 3x1,5) Materiale marunte (cleme, papuci, sirma, banda izol.) din val.mat.explicitate=1,05	m	32,00

37	RpEE01A	Montarea interupatoarelor unipolare sau bipolare de 10-25 A, de constructie normala, impermeabile sau etanse in carcasa de aminoplast, bachelita, metalica sau portelan, montate ingropat sau aparent pe dibluri din lemn sau plastic, racordate la conductori de cupru sau aluminiu	buc	2,00
----	---------	--	-----	------

1	2	3	4	5
38	RpEE03A	Montarea prizelor bipolare constructie normala din bachelita sau aminoplast, simpla, dubla, constructie impermeabila, etanse, etanse metalica sau similare, montate ingropat sub tencuiala sau aparent pe dibluri din lemn sau plastic	buc	2,00
39	RpEF01B	Montarea corpurilor de iluminat, de plafon sau de perete, complet echipate Materiale marunte (banda izol., dibluri, etc.)=1,04	buc	5,00
40	RpIB11A	Demontari radiatoare de pozitie pentru desfiintare	m2	1,00
41	RpSA01B	Demontarea tevii din otel pentru instalatii, zincata, existenta in interiorul cladirii, in pamint avind diametru de 1 1/4"-2"	m	12,00
42	SA14C	Teava din material plastic imbinata prin sudura prin polifuziune, la constructii industriale, avind diametrul de 25 mm	m	12,00
43	SA35A	Fitinguri din fonta maleabila, montate prin insurubare la tevi din otel pentru instalatii zincate, la coloane pentru hidranti interiori, teava avind diametrul de pina la 1" Material marunt (cinepa fuior, grund miniu)=1,01	buc	4,00
44	ID01A	Robinet cu ventil cu dublu reglaj (tur sau retur) pentru instalatii de incalzire central, avind diametrul nominal de 3/8" -1/2"	buc	4,00
45	IB06A	Radiatoare din otel, monobloc avind lungimea de 1000 mm(fara pret -asigurate de catre beneficiar)	buc	2,00

Existent

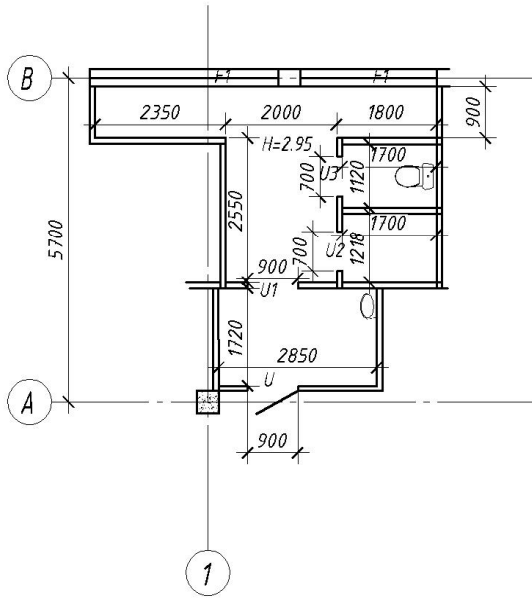

PROPUS

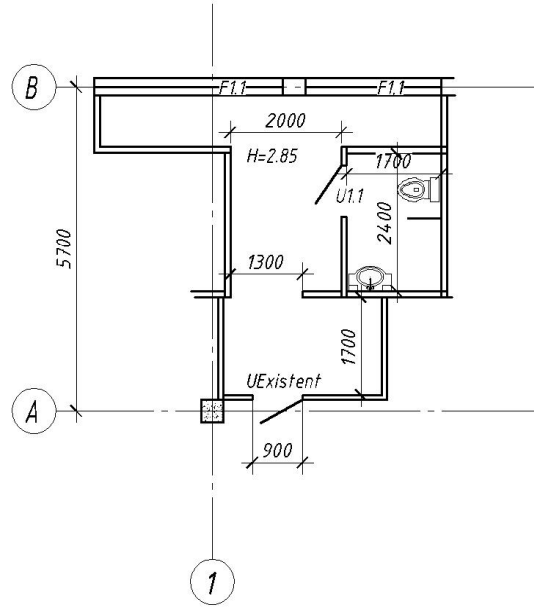

(position, signature, name, surname)

**TECHNICAL SPECIFICATIONS
FOR PRICE QUOTATION**

1. Name of the beneficiary: UNICEF Moldova, for Ungheni HC PHCF.
2. Organizer of the procurement procedure: UNICEF Moldova, for Ungheni HC PHCF.
3. Object of procurement: Renovation works of 2 double sanitary groups

No.	Symbol of the norm and resource code	Name of works	Unit of measure	Volume
1	2	3	4	5
		Chapter 1. Sanitary block floor 1 (double)		
1	RpCM33A	Dismantling the plates of floor tiles, ceramics, and pottery	m2	30.67
2	RpVD07D	Manual transport of materials, in free and undisturbed spaces, carried out by direct transport for the first 10 m horizontal distance with a load of 50 kg for each transport at a distance of no more than 60 m.	t	3.00
3		Transporting construction waste	t	3.00
4	RpCO56A	Dismantling of the wooden carpeting (doors, windows, shutter, rolls, cases, masks, etc.)	m2	4.40
5	CK25A1	Installation of PVC profiles single-leaf doors including the fittings and necessary accessories for them, with frame area up to 7 m ² inclusively, in any type of masonry, in buildings with height of over 35 m	m2	4.40
6	CG01A	Supporting layer for flooring executed from cement mortar M 100-T of 3 cm thickness with delicately smoothed surface	m2	7.52
7	CG47D	Ceramic tile floors, including the support layer from adhesives (dry mix) , plaque size : 300 x 300 mm	m2	7.52
8	RpCJ12B1	Interior and exterior plastering trowel, executed in cement mortar M 100-T of 2 cm average thickness, for walls from concrete or bricks, with with curved surfaces, for glazed plaster on ceilings	m2	23.15

1	2	3	4	5
9	CI22B	Ceramic tile plywood (on walls, columns, pilasters and window sills) fixed with adhesive (dry mixture), plates' size: up to 200 x 200 mm	m2	23.15
10	CN53A	Coating the internal surfaces of the walls and ceilings	m2	14.35
11	RpCJ27C	Miscellaneous - fleece layer of fiberglass applied to the surface made of autoclaved aerated concrete, bonded with glue, including the primer layer	m2	14.35
12	CN53A	Coating the internal surfaces of the walls and ceilings	m2	14.35
13	CF50B	Interior coating of 3 mm thickness, executed manually, with gypsum-based dry mixture, for walls and dividing walls, manual preparation of the mortar.	m2	14.35
14	CF57A	Manual application of the gypsum-based putty "Eurofin" thickness 1,0 mm on the ceilings', walls' and columns' surfaces.	m2	14.35
15	CN06A	Interior painting with paints based on vinyl copolymers in water emulsion, applied in 2 layers on the existing fillings, executed manually.	m2	14.35
16	RpEF23A	Dismantling lighting fittings of any type, including the rods and globes	pcs	3.00
17	CF59D	Coating the surfaces with a layer of plasterboards executing the simple plain metallic carcass, with the height up to 4 m: ceilings without insulation	m2	7.52
18	CN53A	Coating the internal surfaces of the walls and ceilings	m2	7.52
19	CF57A	Manual application of the gypsum-based putty "Eurofin" thickness 1,0 mm on the ceilings', walls' and columns' surfaces.	m2	7.52
20	CN53A	Coating the internal surfaces of the walls and ceilings	m2	7.52
21	CN06A	Interior painting with paints based on vinyl copolymers in water emulsion, applied in 2 layers on the existing fillings, executed manually.	m2	7.52

1	2	3	4	5
22	RpEF13A	Assembling the light fittings of 60 W	pcs	3.00
23	RpSC21A	Mounting the sink from sanitary semi-porcelain or porcelain, etc. including for disabled people, with the sewerage pipe of plastic material, mounted on a console on brick walls or autoclaved aerated concrete walls	pcs	2.00
24	SD04A	The static mixing battery with swinging boom for the washbasin or sink, regardless of the switch-off model, including for disabled people, with the diameter of 1/2"	pcs	2.00
25	SC07A	Closet reservoir, completely equipped, from sanitary semi-porcelain or porcelain etc. including for disabled people, placed on the floor, with the water reservoir mounted at a certain height or semi-height, with the S-type internal siphon	pcs	2.00
26	CL20A	Ready-made ventilation grilles made of blackboard with manually adjustable blinds, painted and mounted in masonry.	pcs	2.00
27	SE44A	Electrical water heater, having the capacity of up to 30 liters, mounted on consoles fixed into the wall	pcs	2.00
28	SD05A	Shut off valves, straight or angle, installed in front of the plumbing fixtures, with diameters of 3/8" – 1/2"	pcs	10.00
29	IC30D	Soft cast iron fittings, with 2 screw-threads, assembled by bolting with the steel pipe, having the diameter up to 1"	pcs	4.00
30	RpEG03A	Installing the distribution panels consisting of panel, cabinet, cell or desk, ready equipped, with a weight up to 150 kg	pcs	1.00
31	RpED09A	Installing electrical copper cables with PVC insulation, with high resistance to propagation of flames, for pressure of 0,6/1 kV, symbol CYYF, mounted apparently, having the section of 3x2,5 mm ²	m	22.50
32	RpEE15A	Assembling switchers - single-pole switcher 25 A - symbol 3129 N	pcs	7.00
33	RpEE03A	Assembling bipolar sockets in normal constructions from bakelite or amino-plastic, simple, double, water-proof construction, seals,	pcs	5.00

1	2	3	4	5
		metallic or similar seals, assembled under coating or visibly on the wood or plastic gimlets		
34	IC36A	High density reinforced polyethylene or reinforced or non-reinforced polypropylene pipe, mounted in columns at the central heating installations, with the external diameter of 20.0 mm inclusively	m	7.50
35	IC37B	Fittings with two joints from polyethylene joined by pressed screwing with the reinforced polyethylene pipe, having the exterior diameter of 20.0 mm / sleeve, T-bend, bend 20 / 1/2Fe /	pcs	14.00
36	IC38A	The fitting piece, with 2 joints, from combined polypropylene through poly-fusion with the pipe from reinforced polypropylene having the exterior diameter of 20,0 mm, inclusively	pcs	25.00
37	RpSB13E	Mounting the plastic sewer pipe, combined with rubber case, surface-mounted or buried under the floor, having a diameter of 110 mm	m	4.00
38	RpSB13C	Installing plastic sewer pipe , combined with rubber case, surface-mounted or buried under the floor, having a diameter of 50 mm	m	4.00
39	RpSB14E	Installing the linking piece from plastic for sewerage, combined with rubber case, having a diameter of 110 mm	pcs	8.00
40	RpSB14C	Installing the linking piece from plastic for sewerage, combined with rubber case, having a diameter of 50 mm	pcs	9.00
		Chapter 2. Sanitary block floor 3 (double)		
41	RpCM33A	Dismantling the plates of floor tiles, ceramics, and pottery	m2	30.67
42	RpVD07D	Manual transport of materials, in free and undisturbed spaces, carried out by direct transport for the first 10 m horizontal distance with a load of 50 kg for each transport at a distance of no more than 60 m.	t	3.00
43		Transporting construction waste	t	3.00
44	CG01A	Supporting layer for flooring executed from cement mortar M 100-T of 3 cm thickness with delicately smoothed surface	m2	7.52

1	2	3	4	5
45	CG47D	Ceramic tile floors, including the support layer from adhesives (dry mix) , plaque size : 300 x 300 mm	m2	7.52
46	RpCJ12B1	Interior and exterior plastering trowel, executed in cement mortar M 100-T of 2 cm average thickness, for walls from concrete or bricks, with with curved surfaces, for glazed plaster on ceilings	m2	23.15
47	CI22B	Ceramic tile plywood (on walls, columns, pilasters and window sills) fixed with adhesive (dry mixture), plates' size: up to 200 x 200 mm	m2	23.15
48	CN53A	Coating the internal surfaces of the walls and ceilings	m2	14.35
49	RpCJ27C	Miscellaneous - fleece layer of fiberglass applied to the surface made of autoclaved aerated concrete, bonded with glue, including the primer layer	m2	14.35
50	CN53A	Coating the internal surfaces of the walls and ceilings	m2	14.35
51	CF50B	Interior coating of 3 mm thickness, executed manually, with gypsum-based dry mixture, for walls and dividing walls, manual preparation of the mortar.	m2	14.35
52	CF57A	Manual application of the gypsum-based putty "Eurofin" thickness 1,0 mm on the ceilings', walls' and columns' surfaces.	m2	14.35
53	CN06A	Interior painting with paints based on vinyl copolymers in water emulsion, applied in 2 layers on the existing fillings, executed manually.	m2	14.35
54	RpEF23A	Dismantling lighting fittings of any type, including the rods and globes	pcs	3.00
55	CF59D	Coating the surfaces with a layer of plasterboards executing the simple plain metallic carcass, with the height up to 4 m: ceilings without insulation	m2	7.52
56	CN53A	Coating the internal surfaces of the walls and ceilings	m2	7.52

1	2	3	4	5
57	CF57A	Manual application of the gypsum-based putty "Eurofin" thickness 1,0 mm on the ceilings', walls' and columns' surfaces.	m2	7.52
58	CN53A	Coating the internal surfaces of the walls and ceilings	m2	7.52
59	CN06A	Interior painting with paints based on vinyl copolymers in water emulsion, applied in 2 layers on the existing fillings, executed manually.	m2	7.52
60	RpEF13A	Assembling the light fittings of 60 W	pcs	3.00
61	RpSC21A	Mounting the sink from sanitary semi-porcelain or porcelain, etc. including for disabled people, with the sewerage pipe of plastic material, mounted on a console on brick walls or autoclaved aerated concrete walls	pcs	2.00
62	SD04A	The static mixing battery with swinging boom for the washbasin or sink, regardless of the switch-off model, including for disabled people, with the diameter of 1/2"	pcs	2.00
63	SC07A	Closet reservoir, completely equipped, from sanitary semi-porcelain or porcelain etc. including for disabled people, placed on the floor, with the water reservoir mounted at a certain height or semi-height, with the S-type internal siphon	pcs	2.00
64	CL20A	Ready-made ventilation grilles made of blackboard with manually adjustable blinds, painted and mounted in masonry.	pcs	2.00
65	SE44A	Electrical water heater, having the capacity of up to 30 liters, mounted on consoles fixed into the wall	pcs	2.00
66	SD05A	Shut off valves, straight or angle, installed in front of the plumbing fixtures, with diameters of 3/8" – 1/2"	pcs	10.00
67	IC30D	Soft cast iron fittings, with 2 screw-threads, assembled by bolting with the steel pipe, having the diameter up to 1"	pcs	4.00
68	RpEG03A	Installing the distribution panels consisting of panel, cabinet, cell or desk, ready equipped, with a weight up to 150 kg	pcs	1.00

1	2	3	4	5
69	RpED09A	Installing electrical copper cables with PVC insulation, with high resistance to propagation of flames, for pressure of 0,6/1 kV, symbol CYYF, mounted apparently, having the section of 3x2,5 mm ²	m	22.50
70	RpEE15A	Assembling switchers - single-pole switcher 25 A - symbol 3129 N	pcs	7.00
71	RpEE03A	Assembling bipolar sockets in normal constructions from bakelite or amino-plastic, simple, double, water-proof construction, seals, metallic or similar seals, assembled under coating or visibly on the wood or plastic gimlets	pcs	5.00
72	IC36A	High density reinforced polyethylene or reinforced or non-reinforced polypropylene pipe, mounted in columns at the central heating installations, with the external diameter of 20.0 mm inclusively	m	7.50
73	IC37B	Fittings with two joints from polyethylene joined by pressed screwing with the reinforced polyethylene pipe, having the exterior diameter of 20.0 mm / sleeve, T-bend, bend 20 / 1/2Fe /	pcs	14.00
74	IC38A	The fitting piece, with 2 joins, from combined polypropylene through poly-fusion with the pipe from reinforced polypropylene having the exterior diameter of 20,0 mm, inclusively	pcs	25.00
75	RpSB13E	Mounting the plastic sewer pipe, combined with rubber case, surface-mounted or buried under the floor, having a diameter of 110 mm	m	4.00
76	RpSB13C	Installing plastic sewer pipe , combined with rubber case, surface-mounted or buried under the floor, having a diameter of 50 mm	m	4.00
77	RpSB14E	Installing the linking piece from plastic for sewerage, combined with rubber case, having a diameter of 110 mm	pcs	8.00
78	RpSB14C	Installing the linking piece from plastic for sewerage, combined with rubber case, having a diameter of 50 mm	pcs	9.00

Romanian Version, Ungheni PHCF

CAIET DE SARCINI PENTRU CEREREA OFERTEI DE PREȚ

1. Denumirea beneficiarului: UNICEF Moldova, pentru IMSP CS Ungheni.
2. Organizatorul procedurii de achiziție: UNICEF Moldova, pentru IMSP CS Ungheni.
3. Obiectul achizițiilor: **Lucrari de reparatii a 2 grupuri sanitare duble**

№ crt.	Simbol norme si cod resurse	Denumire lucrărilor	Unitatea de măsură	Volum
1	2	3	4	5
		Capitolul 1. Bloc sanitar et. 1 (dublu)		
1	RpCM33A	Demontarea placajelor din faianta, gresie, ceramica	m2	30,67
2	RpVD07D	Transportul manual al materialelor, in spatii libere si neaccidentate, executat prin purtat direct pentru primii 10 m distanta orizontala cu o incarcatura de 50 kg la fiecare transport la o distanta de cel mult 60 m	t	3,00
3		Transportarea deseurilor de constructie	t	3,00
4	RpCO56A	Demontari: timplarie din lemn (usi, ferestre, obloane, cutii, rulou, masti, etc.)	m2	4,40
5	CK25A1	Usi confectionate din profiluri din mase plastice inclusiv armaturile si accesoriile necesare usilor montate in zidarie de orice natura la constructii cu inaltimea peste 35 m intr-un canat, cu suprafata tocului pina la 7 mp inclusiv	m2	4,40
6	CG01A	Strat suport pentru pardoseli executat din mortar din ciment M 100-T de 3 cm grosime cu fata driscuita fin	m2	7,52
7	CG47D	Pardoseli din placi de gresie ceramica, inclusiv stratul suport din adezivi (amestec uscat), dimensiuni placi: peste 300 x 300 mm	m2	7,52
8	RpCJ12B1	Tencuieli interioare si exterioare sclivisite, executate cu mortar de ciment M 100-T de 2 cm grosime medie, la pereti din beton sau caramida, cu suprafete curbe, pentru tencuieli sclivisite la tavane	m2	23,15

1	2	3	4	5
9	CI22B	Placaj din placute de ceramica (la pereti, stilpi, pilastri si glafuri) fixate de adeziv (amestec uscat), dimensiuni placute: pina la 200 x 200 mm	m2	23,15
10	CN53A	Grunduirea suprafetelor interioare a peretilor si tavanelor	m2	14,35
11	RpCJ27C	Diverse lucrari - strat de impislitura din fibre de sticla aplicat pe suprafetele din BCA lipit cu aracet inclusiv stratul de amorsaj	m2	14,35
12	CN53A	Grunduirea suprafetelor interioare a peretilor si tavanelor	m2	14,35
13	CF50B	Tencuieli interioare de 3 mm grosime, executate manual, cu amestec uscat pe baza de ipsos, la pereti si pereti despartitori, preparare manuala a mortarului.	m2	14,35
14	CF57A	Aplicarea manuala a chitului pe baza de ipsos "Eurofin" grosime 1,0 mm pe suprafetele peretilor, coloanelor si tavanelor	m2	14,35
15	CN06A	Vopsitorii interioare cu vopsea pe baza de copolimeri vinilici in emulsie apoasa, aplicate in 2 straturi pe glet existent, executate manual	m2	14,35
16	RpEF23A	Demontari de corpuri de iluminat orice tip, inclusiv tije si globurile	buc	3,00
17	CF59D	Placarea suprafetelor cu un strat de PGC cu executarea carcasi metalice simple plane, cu inaltimea pina la 4 m: tavane fara izolatie	m2	7,52
18	CN53A	Grunduirea suprafetelor interioare a peretilor si tavanelor	m2	7,52
19	CF57A	Aplicarea manuala a chitului pe baza de ipsos "Eurofin" grosime 1,0 mm pe suprafetele peretilor, coloanelor si tavanelor	m2	7,52
20	CN53A	Grunduirea suprafetelor interioare a peretilor si tavanelor	m2	7,52
21	CN06A	Vopsitorii interioare cu vopsea pe baza de copolimeri vinilici in emulsie apoasa, aplicate in 2 straturi pe glet existent, executate manual	m2	7,52
22	RpEF13A	Montarea corpurilor de iluminat de 60 W	buc	3,00

1	2	3	4	5
23	RpSC21A	Montarea lavoarului din semiportelan, portelan sanitar etc. inclusiv pentru handicapati, avind teava de scurgere din material plastic, montat pe console fixate pe pereti din zidarie de caramida sau b.c.a.	buc	2,00
24	SD04A	Baterie amestecatoare cu brat basculant stativa pentru lavoar sau spalator, indiferent de modul de inchidere, inclusiv pentru handicapati, avind diametrul de 1/2"	buc	2,00
25	SC07A	Vas pentru closet, complet echipat, din semiportelan, portelan sanitar etc. inclusiv pentru handicapati, asezat pe pardoseala, cu rezervorul de apa montat la inaltime sau semiinaltime, avind sifonul interior tip S	buc	2,00
26	CL20A	Grile de ventilatie gata confectionate din tabla neagra, cu jaluzele reglabile manual, vopsite si montate in zidarie.	buc	2,00
27	SE44A	Incalzitor de apa electric, avind capacitatea de pina la 30 l, montata pe console fixate in perete	buc	2,00
28	SD05A	Robinet de reglaj, drept sau coltar, montat inaintea armaturii de la obiectele sanitare, avind diametrul de 3/8" - 1/2"	buc	10,00
29	IC30D	Fitinguri din fonta maleabila, avind 2 insurubari, montata prin insurubare cu teava de otel, avind diametrul pina la 1"	buc	4,00
30	RpEG03A	Montarea tablourilor de distributie format panou, dulap, celula sau pupitru, gata echipate, avind greutatea pina la 150 kg	buc	1,00
31	RpED09A	Montarea cablurilor electrice din cupru, cu izolatie din PVC, cu rezistenta marita la propagarea flacarilor, pentru tensiuni de 0,6/1 kV, simbol CYYF, montate aparent, avind sectiunea de 3x2,5 mmp	m	22,50
32	RpEE15A	Montarea intrerupatoarelor - intrerupator monopolar 25 A- simbol 3129 N	buc	7,00
33	RpEE03A	Montarea prizelor bipolare constructie normala din bachelita sau aminoplast, simpla, dubla, constructie impermeabila, etanse, etanse metalica sau similare, montate ingropat sub tencuiala sau aparent pe dibluri din lemn sau plastic	buc	5,00

1	2	3	4	5
34	IC36A	Teava din polietilena armata de inalta densitate sau polipropilena armata sau nearmata, montata in coloane la instalatii de incalzire centrala, avind diametrul exterior de pina la 20,0 mm, inclusiv.	m	7,50
35	IC37B	Piese de racordare cu doua imbinari (fitinguri) din polietilena, imbinate prin infiletare cu teava din polietilena armata, avind diametrul exterior de 20,0 mm / mufa,teu,cot 20 / 1/2Fe /	buc	14,00
36	IC38A	Piesa de racordare (fiting), cu 2 imbinari, din polipropilena imbinate prin polifusiune cu teava din polipropilena armata, avind diametrul exterior de pina la 20,0 mm, inclusiv	buc	25,00
37	RpSB13E	Montarea tevii din material plastic pentru canalizare, imbinata cu garnitura de cauciuc, montata aparent sau ingropat sub pardoseala, avind diametrul de 110 mm	m	4,00
38	RpSB13C	Montarea tevii din material plastic pentru canalizare, imbinata cu garnitura de cauciuc, montata aparent sau ingropat sub pardoseala, avind diametrul de 50 mm	m	4,00
39	RpSB14E	Montarea piesei de legatura din material plastic pentru canalizare, imbinata cu garnitura de cauciuc, avind diametrul de 110 mm	buc	8,00
40	RpSB14C	Montarea piesei de legatura din material plastic pentru canalizare, imbinata cu garnitura de cauciuc, avind diametrul de 50 mm	buc	9,00
		Capitolul 2. Bloc sanitar et. 3 (dublu)		
41	RpCM33A	Demontarea placajelor din faianta, gresie, ceramica	m2	30,67
42	RpVD07D	Transportul manual al materialelor, in spatii libere si neaccidentate, executat prin purtat direct pentru primii 10 m distanta orizontala cu o incarcatura de 50 kg la fiecare transport la o distanta de cel mult 60 m	t	3,00
43		Transportarea deseurilor de constructie	t	3,00
44	CG01A	Strat suport pentru pardoseli executat din mortar din ciment M 100-T de 3 cm grosime cu fata driscuita fin	m2	7,52

1	2	3	4	5
45	CG47D	Pardoseli din placi de gresie ceramica, inclusiv stratul suport din adezivi (amestec uscat), dimensiuni placi: peste 300 x 300 mm	m2	7,52
46	RpCJ12B1	Tencuieli interioare si exterioare sclivisite, executate cu mortar de ciment M 100-T de 2 cm grosime medie, la pereti din beton sau caramida, cu suprafete curbe, pentru tencuieli sclivisite la tavane	m2	23,15
47	CI22B	Placaj din placute de ceramica (la pereti, stilpi, pilastri si glafuri) fixate de adeziv (amestec uscat), dimensiuni placute: pina la 200 x 200 mm	m2	23,15
48	CN53A	Grunduirea suprafetelor interioare a peretilor si tavanelor	m2	14,35
49	RpCJ27C	Diverse lucrari - strat de impislitura din fibre de sticla aplicat pe suprafetele din BCA lipit cu aracet inclusiv stratul de amorsaj	m2	14,35
50	CN53A	Grunduirea suprafetelor interioare a peretilor si tavanelor	m2	14,35
51	CF50B	Tencuieli interioare de 3 mm grosime, executate manual, cu amestec uscat pe baza de ipsos, la pereti si pereti despartitori, preparare manuala a mortarului.	m2	14,35
52	CF57A	Aplicarea manuala a chitului pe baza de ipsos "Eurofin" grosime 1,0 mm pe suprafetele peretilor, coloanelor si tavanelor	m2	14,35
53	CN06A	Vopsitorii interioare cu vopsea pe baza de copolimeri vinilici in emulsie apoasa, aplicate in 2 straturi pe glet existent, executate manual	m2	14,35
54	RpEF23A	Demontari de corpuri de iluminat orice tip, inclusiv tije si globurile	buc	3,00
55	CF59D	Placarea suprafetelor cu un strat de PGC (rezistente la umiditate) cu executarea carcasei metalice simple plane, cu inaltimea pina la 4 m: tavane fara izolatie	m2	7,52
56	CN53A	Grunduirea suprafetelor interioare a peretilor si tavanelor	m2	7,52
57	CF57A	Aplicarea manuala a chitului pe baza de ipsos "Eurofin" grosime 1,0 mm pe suprafetele peretilor, coloanelor si tavanelor	m2	7,52

1	2	3	4	5
58	CN53A	Grunduirea suprafetelor interioare a peretilor si tavanelor	m2	7,52
59	CN06A	Vopsitorii interioare cu vopsea pe baza de copolimeri vinilici in emulsie apoasa, aplicate in 2 straturi pe glet existent, executate manual	m2	7,52
60	RpEF13A	Montarea corpurilor de iluminat de 60 W	buc	3,00
61	RpSC21A	Montarea lavoarului din semiportelan, portelan sanitar etc. inclusiv pentru handicapati, avind teava de scurgere din material plastic, montat pe console fixate pe pereti din zidarie de caramida sau b.c.a.	buc	2,00
62	SD04A	Baterie amestecatoare cu brat basculant stativa pentru lavoar sau spalator, indiferent de modul de inchidere, inclusiv pentru handicapati, avind diametrul de 1/2"	buc	2,00
63	SC07A	Vas pentru closet, complet echipat, din semiportelan, portelan sanitar etc. inclusiv pentru handicapati, asezat pe pardoseala, cu rezervorul de apa montat la inaltime sau semiinaltime, avind sifonul interior tip S	buc	2,00
64	CL20A	Grile de ventilatie gata confectionate din tabla neagra, cu jaluzele reglabile manual, vopsite si montate in zidarie.	buc	2,00
65	SE44A	Incalzitor de apa electric, avind capacitatea de pina la 30 l, montata pe console fixate in perete	buc	2,00
66	SD05A	Robinet de reglaj, drept sau coltar, montat inaintea armaturii de la obiectele sanitare, avind diametrul de 3/8" - 1/2"	buc	10,00
67	IC30D	Fitinguri din fonta maleabila, avind 2 insurubari, montata prin insurubare cu teava de otel, avind diametrul pina la 1"	buc	4,00
68	RpEG03A	Montarea tablourilor de distributie format panou, dulap, celula sau pupitru, gata echipate, avind greutatea pina la 150 kg	buc	1,00
69	RpED09A	Montarea cablurilor electrice din cupru, cu izolatie din PVC, cu rezistenta marita la propagarea flacarilor, pentru tensiuni de 0,6/1 kV, simbol CYYF, montate aparent, avind sectiunea de 3x2,5 mmp	m	22,50

1	2	3	4	5
70	RpEE15A	Montarea intrerupatoarelor - intrerupator monopolar 25 A- simbol 3129 N	buc	7,00
71	RpEE03A	Montarea prizelor bipolare constructie normala din bachelita sau aminoplast, simpla, dubla, constructie impermeabila, etanse, etanse metalica sau similare, montate ingropat sub tencuiala sau aparent pe dibluri din lemn sau plastic	buc	5,00
72	IC36A	Teava din polietilena armata de inalta densitate sau polipropilena armata sau nearmata, montata in coloane la instalatii de incalzire centrala, avind diametrul exterior de pina la 20,0 mm, inclusiv.	m	8,50
73	IC37B	Piese de racordare cu doua imbinari (fitinguri) din polietilena, imbinate prin infiletare cu teava din polietilena armata, avind diametrul exterior de 20,0 mm / mufa,teu,cot 20 / 1/2Fe /	buc	14,00
74	IC38A	Piesa de racordare (fiting), cu 2 imbinari, din polipropilena imbinate prin polifusiune cu teava din polipropilena armata, avind diametrul exterior de pina la 20,0 mm, inclusiv	buc	25,00
75	RpSB13E	Montarea tevii din material plastic pentru canalizare, imbinata cu garnitura de cauciuc, montata aparent sau ingropat sub pardoseala, avind diametrul de 110 mm	m	4,00
76	RpSB13C	Montarea tevii din material plastic pentru canalizare, imbinata cu garnitura de cauciuc, montata aparent sau ingropat sub pardoseala, avind diametrul de 50 mm	m	4,00
77	RpSB14E	Montarea piesei de legatura din material plastic pentru canalizare, imbinata cu garnitura de cauciuc, avind diametrul de 110 mm	buc	8,00
78	RpSB14C	Montarea piesei de legatura din material plastic pentru canalizare, imbinata cu garnitura de cauciuc, avind diametrul de 50 mm	buc	9,00

Beneficiar

(funcția, semnătura)

Ofertant

